

# ВОРФИТ ФИТИНГИ ЗА ЧЕЛНА ЗАВАРКА

Осигурете здрава и монолитна връзка.

# ИНЖЕКЦИОННО ЛЯТИ ФИТИНГИ ЗА ВОДО- РАЗПРЕДЕЛИТЕЛНИ СИСТЕМИ

Челното заваряване е технология, известна от десетилетия, която се използва за свързване на тръби и фитинги от полиетилен. Свързването се извършва чрез специална машина, която захваща двата елемента, които ще бъдат свързвани и ги притиска до нагревателна плоча с термостат. Нагнетите (разтопени) краища се притискат един към друг и след тяхното охлаждане се образува шев т.е. монолитна структура на връзката.

Предимствата, които Ви осигурява челното заваряване са здрава и монолитна връзка, лесна механична обработка на елементите и контрол на изкривяването. Възможни са и различни форми на заваряване.

За да предложим висококачествено и завършено решение на нашите клиенти, не правим компромис с качеството на нито една част. Работим съвместно с внимателно подбрани и доказали се брандове на пазара, какъвто е Turan Makina & Borfit!

Основана през 1995 Turan Makina & Borfit с производство и седалище в Истанбул е една от водещите марки в сферата на фитингите челна заварка за водо- и газоснабдяване в повече от **50** страни по света.

## ПРОДУКТОВА МАРКИРОВКА

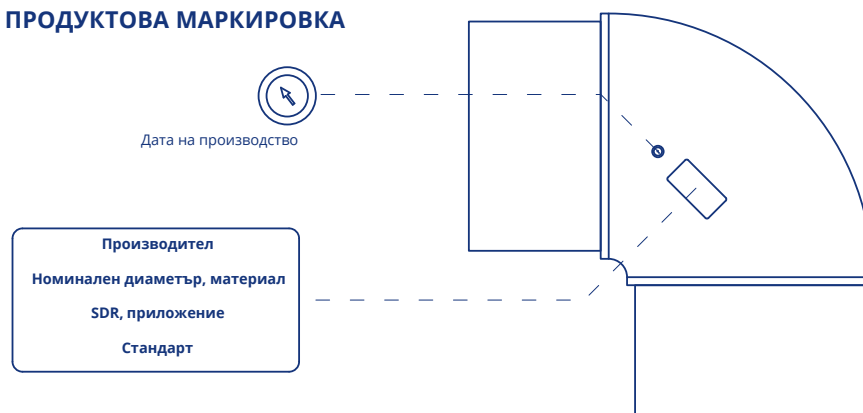

# КОЛЯНО, ЧЕЛНА ЗАВАРКА

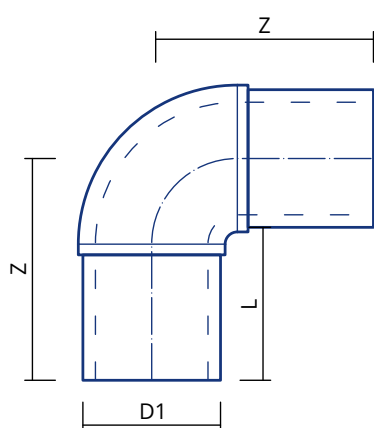

Размер D1 (mm)	PN	L (mm)	Z (mm)	Тегло (kg)	Материал
20	PN16	50	75	0.02	PEHD
25	PN16	50	81	0.03	PEHD
32	PN16	54	86	0.05	PEHD
40	PN16	57	91	0.08	PEHD
50	PN16	60	103	0.15	PEHD
63	PN16	63	113	0.24	PEHD
75	PN16	70	130	0.38	PEHD
90	PN10	82	145	0.47	PEHD
90	PN16	82	145	0.65	PEHD
110	PN10	85	160	0.76	PEHD
110	PN16	85	160	1.03	PEHD
125	PN10	90	175	1.13	PEHD
125	PN16	90	175	1.48	PEHD
140	PN10	115	195	1.46	PEHD
140	PN16	115	195	2.00	PEHD
160	PN10	103	200	2.10	PEHD
160	PN16	103	200	2.76	PEHD
180	PN10	105	226	3.57	PEHD
180	PN16	105	226	3.90	PEHD
200	PN10	115	245	4.36	PEHD
200	PN16	115	245	5.33	PEHD
225	PN10	120	260	4.95	PEHD
225	PN16	120	260	6.77	PEHD
250	PN10	130	275	6.77	PEHD
250	PN16	130	275	9.16	PEHD
280	PN10	135	300	8.22	PEHD
280	PN16	135	300	12.32	PEHD
315	PN10	150	350	13.42	PEHD
315	PN16	150	350	18.26	PEHD
355	PN10	145	345	15.88	PEHD
355	PN16	145	345	21.71	PEHD
400	PN10	150	370	21.01	PEHD
400	PN16	150	370	30.18	PEHD
450	PN10	170	445	30.96	PEHD
450	PN16	170	445	43.88	PEHD
500	PN10	185	485	42.18	PEHD
500	PN16	185	485	59.00	PEHD
560	PN10	100	435	47.02	PEHD
560	PN16	100	435	66.14	PEHD
630	PN10	100	470	63.90	PEHD
630	PN16	100	470	90.11	PEHD

# ДЪГА, ЧЕЛНА ЗАВАРКА

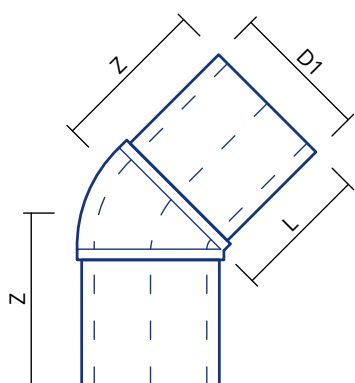

Размер D1 (mm)	PN	L (mm)	Z (mm)	Тегло (kg)	Материал
20	PN16	36	42	0.02	PEHD
25	PN16	40	50	0.03	PEHD
32	PN16	55	80	0.05	PEHD
40	PN16	55	85	0.08	PEHD
50	PN16	60	95	0.12	PEHD
63	PN16	65	90	0.21	PEHD
75	PN16	70	100	0.31	PEHD
90	PN16	80	120	0.54	PEHD
110	PN10	85	125	0.63	PEHD
110	PN16	85	125	0.83	PEHD
125	PN16	90	135	1.21	PEHD
140	PN16	100	130	1.43	PEHD
160	PN10	100	160	1.60	PEHD
160	PN16	100	160	2.19	PEHD
180	PN10	110	165	2.03	PEHD
180	PN16	110	165	2.97	PEHD
200	PN10	115	180	2.92	PEHD
200	PN16	115	180	3.84	PEHD
225	PN10	120	185	3.84	PEHD
225	PN16	120	185	5.35	PEHD
250	PN10	130	210	5.19	PEHD
250	PN16	130	210	7.12	PEHD
280	PN10	135	220	6.93	PEHD
280	PN16	135	220	9.77	PEHD
315	PN10	145	240	9.90	PEHD
315	PN16	145	240	12.59	PEHD
355	PN10	145	230	10.78	PEHD
355	PN16	145	230	15.38	PEHD
400	PN10	145	253	15.21	PEHD
400	PN16	145	253	21.63	PEHD
450	PN10	170	310	23.06	PEHD
450	PN16	170	310	33.00	PEHD
500	PN10	185	335	31.08	PEHD
500	PN16	185	335	44.00	PEHD
560	PN10	100	265	31.74	PEHD
560	PN16	100	265	45.04	PEHD
630	PN10	100	280	42.24	PEHD
630	PN16	100	280	60.10	PEHD

# ТРОЙНИК, ЧЕЛНА ЗАВАРКА

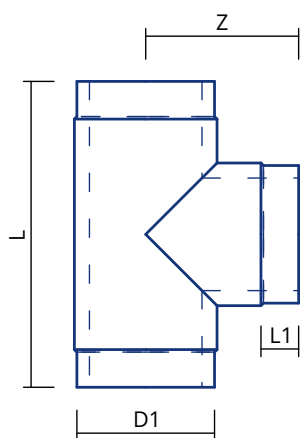

Размер D1 (mm)	PN	L (mm)	L1 (mm)	Z (mm)	Тегло (kg)	Материал
20	PN16	145	50	75	0.04	PEHD
25	PN16	155	50	80	0.05	PEHD
32	PN16	170	55	85	0.07	PEHD
40	PN16	190	55	100	0.13	PEHD
50	PN16	225	65	115	0.22	PEHD
63	PN16	225	65	115	0.33	PEHD
75	PN16	260	70	130	0.54	PEHD
90	PN10	270	80	135	0.59	PEHD
90	PN16	270	80	135	0.78	PEHD
110	PN10	300	80	150	0.91	PEHD
110	PN16	300	80	150	1.31	PEHD
125	PN10	365	95	180	1.52	PEHD
125	PN16	365	95	180	2.02	PEHD
140	PN10	390	100	195	2.08	PEHD
140	PN16	390	100	195	2.73	PEHD
160	PN10	400	100	200	2.70	PEHD
160	PN16	400	100	200	3.54	PEHD
180	PN10	455	105	225	3.97	PEHD
180	PN16	455	105	225	5.48	PEHD
200	PN10	490	115	245	5.37	PEHD
200	PN16	490	115	245	7.00	PEHD
225	PN10	520	120	253	6.60	PEHD
225	PN16	520	120	253	8.93	PEHD
250	PN10	550	130	275	9.00	PEHD
250	PN16	550	130	275	11.29	PEHD
280	PN10	590	145	290	11.52	PEHD
280	PN16	590	145	290	15.01	PEHD
315	PN10	670	155	325	17.29	PEHD
315	PN16	670	155	325	22.40	PEHD
355	PN10	730	155	360	21.81	PEHD
355	PN16	730	155	360	29.79	PEHD
400	PN10	785	155	395	30.55	PEHD
400	PN16	785	155	395	41.51	PEHD
450	PN10	890	175	445	44.00	PEHD
450	PN16	890	175	445	62.00	PEHD
500	PN10	780	175	460	55.00	PEHD
500	PN16	780	175	460	80.99	PEHD
560	PN10	900	180	515	72.00	PEHD
630	PN10	920	195	575	110.00	PEHD
630	PN16	920	195	575	140.00	PEHD

# ФЛАНШОВ АДАПТОР, ЧЕЛНА ЗАВАРКА

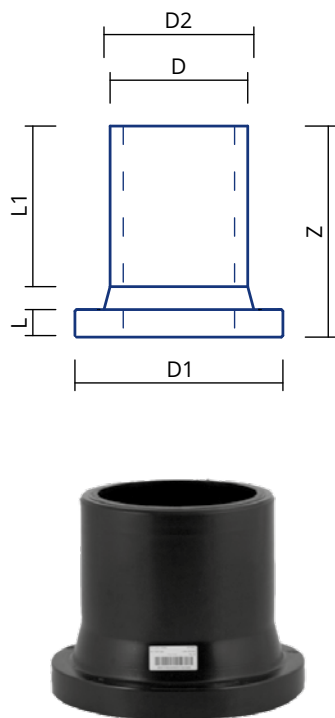

Размер D (mm)	PN	D1 (mm)	D2 (mm)	L (mm)	L1 (mm)	Z (mm)	Тегло (kg)	Материал
20	PN16	27	45	7	43	75	0.03	PEHD
25	PN16	33	58	8	40	82	0.04	PEHD
32	PN16	40	67	9	44	82	0.05	PEHD
40	PN16	50	78	9	61	86	0.08	PEHD
50	PN16	61	88	13	52	84	0.12	PEHD
63	PN16	75	102	15	65	100	0.17	PEHD
75	PN16	89	122	17	84	122	0.29	PEHD
90	PN10	105	138	15	80	120	0.32	PEHD
90	PN16	105	138	15	80	120	0.39	PEHD
110	PN10	122	158	18	100	140	0.50	PEHD
110	PN16	122	158	18	100	140	0.60	PEHD
125	PN10	132	158	22	100	145	0.65	PEHD
125	PN16	132	158	22	100	145	0.83	PEHD
140	PN10	155	188	27	95	150	0.88	PEHD
140	PN16	155	188	27	95	150	1.02	PEHD
160	PN10	175	212	25	110	165	1.18	PEHD
160	PN16	175	212	25	110	165	1.44	PEHD
180	PN10	185	212	30	110	170	1.48	PEHD
180	PN16	185	212	30	110	170	1.74	PEHD
200	PN10	232	268	30	125	185	2.35	PEHD
200	PN16	232	268	30	125	185	2.71	PEHD
225	PN10	235	268	30	110	170	2.34	PEHD
225	PN16	235	268	30	110	170	2.96	PEHD
250	PN10	285	320	30	135	200	3.48	PEHD
250	PN16	285	320	30	135	200	4.46	PEHD
280	PN10	291	320	35	140	220	4.03	PEHD
280	PN16	291	320	35	140	220	4.77	PEHD
315	PN10	335	370	35	155	215	5.15	PEHD
315	PN16	335	370	35	155	215	6.37	PEHD
355	PN10	373	430	35	137	210	6.75	PEHD
355	PN16	373	430	35	137	210	8.25	PEHD
400	PN10	427	482	45	140	221	8.75	PEHD
400	PN16	427	482	45	140	221	11.28	PEHD
450	PN10	460	535	45	175	276	12.47	PEHD
450	PN16	460	535	45	175	276	17.24	PEHD
500	PN10	530	585	48	175	279	16.52	PEHD
500	PN16	530	585	48	175	279	21.37	PEHD
560	PN10	615	685	50	205	305	25.35	PEHD
560	PN16	615	685	50	205	305	30.45	PEHD
630	PN10	640	685	55	255	330	29.10	PEHD
630	PN16	640	685	55	255	330	39.15	PEHD

# КРЪСТАЧ, ЧЕЛНА ЗАВАРКА

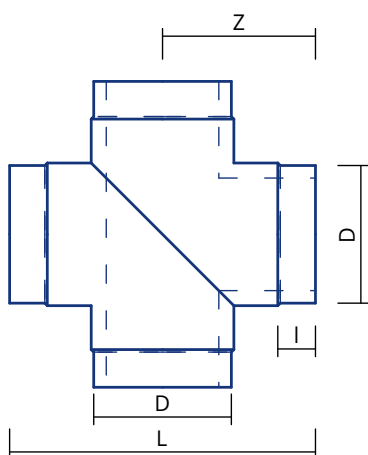

Размер D (mm)	PN	L (mm)	Z (mm)	I (mm)	Тегло (kg)	Материал
110	PN10	310	160	105	1.32	PEHD
110	PN16	310	160	105	1.81	PEHD
160	PN10	400	200	115	3.21	PEHD
160	PN16	400	200	115	4.40	PEHD



# РЕДУКТОР, ЧЕЛНА ЗАВАРКА

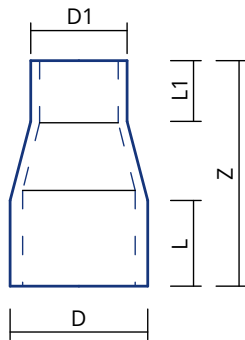

Размер D (mm)	PN	L (mm)	L1 (mm)	Z (mm)	Тегло (kg)	Материал
25-20	PN16	40	35	80	0.01	PEHD
32-20	PN16	50	45	110	0.03	PEHD
32-25	PN16	50	45	110	0.03	PEHD
40-20	PN16	45	45	105	0.03	PEHD
40-25	PN16	45	45	105	0.03	PEHD
40-32	PN16	45	45	105	0.04	PEHD
50-20	PN16	45	45	110	0.04	PEHD
50-25	PN16	45	45	110	0.05	PEHD
50-32	PN16	45	45	110	0.06	PEHD
50-40	PN16	45	45	110	0.09	PEHD
63-20	PN16	50	45	120	0.07	PEHD
63-25	PN16	50	45	120	0.09	PEHD
63-32	PN16	50	45	120	0.08	PEHD
63-40	PN16	50	45	120	0.09	PEHD
63-50	PN16	50	45	120	0.10	PEHD
75-32	PN16	70	50	160	0.15	PEHD
75-40	PN16	70	50	160	0.17	PEHD
75-50	PN16	70	50	160	0.19	PEHD
75-63	PN16	70	50	160	0.21	PEHD
90-32	PN16	80	55	180	0.24	PEHD
90-50	PN16	80	55	180	0.28	PEHD
90-63	PN16	80	55	180	0.31	PEHD
90-75	PN16	80	55	180	0.33	PEHD
110-25	PN16	90	40	200	0.39	PEHD
110-32	PN16	90	50	190	0.38	PEHD
110-50	PN10	90	60	190	0.32	PEHD
110-50	PN16	90	60	190	0.40	PEHD
110-63	PN10	90	65	200	0.32	PEHD
110-63	PN16	90	65	200	0.45	PEHD
110-75	PN16	90	85	190	0.48	PEHD
110-90	PN10	90	85	190	0.39	PEHD
110-90	PN16	90	85	190	0.53	PEHD
125-25	PN16	90	50	210	0.51	PEHD
125-63	PN16	90	60	210	0.56	PEHD
125-75	PN16	90	60	210	0.58	PEHD
125-90	PN10	90	80	210	0.47	PEHD
125-90	PN16	90	80	210	0.65	PEHD
125-110	PN10	80	85	210	0.51	PEHD
125-110	PN16	80	85	210	0.75	PEHD
140-75	PN16	95	70	210	0.76	PEHD
140-90	PN16	95	70	210	0.82	PEHD
140-110	PN10	95	70	210	0.64	PEHD
140-110	PN16	95	70	210	0.93	PEHD
140-125	PN10	95	80	210	0.70	PEHD
140-125	PN16	95	80	210	0.97	PEHD
160-90	PN10	95	75	220	0.74	PEHD
160-90	PN16	95	75	220	1.07	PEHD
160-110	PN10	95	75	220	0.76	PEHD
160-110	PN16	95	75	220	1.15	PEHD
160-125	PN10	95	85	220	0.83	PEHD
160-125	PN16	95	85	220	1.19	PEHD
160-140	PN10	95	85	220	0.87	PEHD
160-140	PN16	95	85	220	1.31	PEHD
180-90	PN10	105	75	250	0.97	PEHD
180-90	PN16	105	75	250	1.35	PEHD
180-110	PN10	105	85	250	1.03	PEHD
180-110	PN16	105	85	250	1.42	PEHD
180-125	PN10	105	90	250	1.08	PEHD
180-125	PN16	105	90	250	1.55	PEHD
180-140	PN10	105	90	250	1.15	PEHD
180-140	PN16	105	90	250	1.74	PEHD
180-160	PN10	105	90	250	1.24	PEHD
180-160	PN16	105	90	250	1.89	PEHD
200-110	PN10	115	85	265	1.49	PEHD
200-110	PN16	115	85	265	1.93	PEHD
200-125	PN10	115	85	265	1.43	PEHD
200-125	PN16	115	85	265	2.04	PEHD



# РЕДУКТОР, ЧЕЛНА ЗАВАРКА

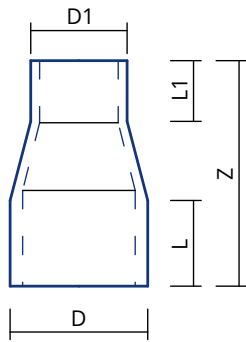

Размер D (mm)	PN	L (mm)	L1 (mm)	Z (mm)	Тегло (kg)	Материал
200-140	PN10	120	100	260	1.45	PEHD
200-140	PN16	120	100	260	1.99	PEHD
200-160	PN10	120	90	255	1.63	PEHD
200-160	PN16	120	90	255	2.24	PEHD
200-180	PN10	120	90	255	1.63	PEHD
200-180	PN16	120	90	255	2.40	PEHD
225-110	PN10	120	80	275	1.82	PEHD
225-110	PN16	120	80	275	2.49	PEHD
225-125	PN10	125	85	280	1.80	PEHD
225-160	PN10	120	100	270	1.77	PEHD
225-160	PN16	125	100	275	2.07	PEHD
225-180	PN10	125	100	25	2.79	PEHD
225-200	PN10	125	105	290	2.33	PEHD
225-200	PN16	120	110	275	2.28	PEHD
250-125	PN16	115	110	275	3.13	PEHD
250-160	PN10	110	80	300	3.25	PEHD
250-160	PN16	110	100	300	2.85	PEHD
250-180	PN10	115	100	300	3.55	PEHD
250-180	PN16	115	100	300	3.89	PEHD
250-200	PN10	115	100	300	4.30	PEHD
250-200	PN16	115	110	300	3.06	PEHD
250-225	PN10	115	110	300	4.30	PEHD
250-225	PN16	115	120	300	3.33	PEHD
280-200	PN10	135	120	330	3.99	PEHD
280-200	PN16	135	110	330	3.94	PEHD
280-225	PN10	135	125	330	5.25	PEHD
280-225	PN16	135	125	330	4.35	PEHD
280-250	PN10	135	125	330	5.38	PEHD
280-250	PN16	135	125	330	4.63	PEHD
315-160	PN10	145	95	335	4.56	PEHD
315-160	PN16	145	95	335	6.28	PEHD
315-200	PN10	145	110	335	4.78	PEHD
315-200	PN16	145	110	335	6.54	PEHD
315-225	PN10	145	110	335	4.88	PEHD
315-225	PN16	145	110	335	6.85	PEHD
315-250	PN10	145	120	335	4.85	PEHD
315-250	PN16	145	120	340	7.29	PEHD
315-280	PN10	145	130	340	5.93	PEHD
315-280	PN16	145	130	360	7.57	PEHD
355-200	PN16	155	115	360	8.44	PEHD
355-250	PN10	155	115	360	6.34	PEHD
355-250	PN16	155	115	360	8.96	PEHD
355-315	PN16	155	115	360	10.46	PEHD
400-200	PN10	140	110	360	7.43	PEHD
400-200	PN16	140	110	360	9.40	PEHD
400-250	PN10	140	110	360	10.58	PEHD
400-315	PN16	140	130	360	8.31	PEHD
400-315	PN10	140	130	360	12.80	PEHD
400-355	PN16	140	150	360	9.56	PEHD
400-355	PN10	140	150	360	12.80	PEHD
500-315	PN16	80	140	260	9.00	PEHD
500-315	PN10	80	140	260	12.00	PEHD
500-355	PN16	80	150	260	9.20	PEHD
500-355	PN10	80	150	260	12.70	PEHD
500-400	PN16	80	158	260	9.75	PEHD
500-400	PN10	80	158	260	13.70	PEHD

# РЕДУКТИВЕН ТРОЙНИК, ЧЕЛНА ЗАВАРКА

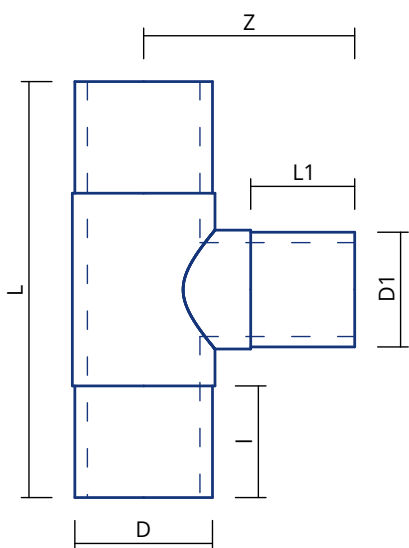

Размер D (mm)	PN	L (mm)	L1 (mm)	Z (mm)	I (mm)	Тегло (kg)	Материал
32-20	PN16	165	55	80	55	0.06	PEHD
32-25	PN16	165	55	80	55	0.07	PEHD
40-20	PN16	190	55	95	55	0.12	PEHD
40-32	PN16	190	55	95	55	0.12	PEHD
50-25	PN16	205	55	95	65	0.17	PEHD
50-32	PN16	205	55	95	65	0.18	PEHD
63-25	PN16	200	55	95	65	0.23	PEHD
63-32	PN16	200	55	95	65	0.22	PEHD
63-40	PN16	200	55	95	65	0.23	PEHD
63-50	PN16	200	55	95	65	0.26	PEHD
75-32	PN16	260	50	105	70	0.30	PEHD
75-40	PN16	260	50	105	70	0.45	PEHD
75-63	PN16	260	50	105	70	0.48	PEHD
90-20	PN16	270	50	110	80	0.64	PEHD
90-25	PN16	270	50	110	80	0.64	PEHD
90-32	PN16	270	55	120	80	0.65	PEHD
90-40	PN16	270	55	120	80	0.67	PEHD
90-50	PN16	295	55	120	80	0.75	PEHD
90-63	PN16	270	65	125	80	0.70	PEHD
90-75	PN16	295	65	125	80	0.83	PEHD
110-25	PN10	250	60	130	80	0.63	PEHD
110-25	PN16	250	60	130	80	0.84	PEHD
110-32	PN10	250	60	130	80	0.62	PEHD
110-32	PN16	250	60	130	80	0.85	PEHD
110-40	PN10	250	60	130	80	0.65	PEHD
110-40	PN16	250	60	130	80	0.85	PEHD
110-50	PN10	250	60	130	80	0.65	PEHD
110-50	PN16	250	60	130	80	0.86	PEHD
110-63	PN10	250	60	130	80	0.69	PEHD
110-63	PN16	250	60	130	80	0.90	PEHD
110-75	PN10	315	70	140	80	0.84	PEHD
110-75	PN16	315	70	140	80	1.14	PEHD
110-90	PN10	315	80	155	85	0.86	PEHD
110-90	PN16	315	80	155	85	1.22	PEHD
125-32	PN16	360	50	125	95	1.61	PEHD
125-63	PN10	360	60	140	95	1.24	PEHD
125-63	PN16	360	60	140	95	1.64	PEHD
125-90	PN16	360	90	160	95	1.76	PEHD
125-110	PN10	360	80	160	95	1.41	PEHD
125-110	PN16	360	80	160	95	1.86	PEHD
140-63	PN10	395	60	165	100	1.79	PEHD
140-63	PN16	395	60	165	100	2.30	PEHD
140-90	PN10	395	80	165	100	1.83	PEHD
140-90	PN16	395	80	165	100	2.36	PEHD
140-110	PN10	395	80	165	100	1.83	PEHD
140-110	PN16	395	80	165	100	2.44	PEHD
160-25	PN16	320	45	155	100	2.28	PEHD
160-32	PN10	320	45	155	100	1.63	PEHD
160-32	PN16	320	45	155	100	2.27	PEHD
160-50	PN10	320	65	160	100	1.60	PEHD
160-50	PN16	320	65	160	100	2.20	PEHD
160-63	PN10	320	65	170	100	1.66	PEHD
160-63	PN16	320	65	170	100	2.32	PEHD
160-75	PN10	320	65	160	100	1.66	PEHD
160-75	PN16	320	65	160	100	2.36	PEHD
160-90	PN10	320	70	165	100	1.70	PEHD
160-90	PN16	320	70	165	100	2.36	PEHD
160-110	PN10	320	85	190	100	1.80	PEHD
160-110	PN16	320	85	190	100	2.52	PEHD
160-140	PN10	320	95	190	100	1.80	PEHD
160-140	PN16	320	95	190	100	2.00	PEHD
180-90	PN10	455	90	195	105	3.30	PEHD
180-90	PN16	455	90	195	105	4.44	PEHD
180-110	PN10	455	100	210	105	3.39	PEHD
180-110	PN16	455	100	210	105	4.65	PEHD
180-125	PN16	455	100	210	105	4.59	PEHD
200-50	PN16	420	60	200	110	4.70	PEHD

# РЕДУКТИВЕН ТРОЙНИК, ЧЕЛНА ЗАВАРКА

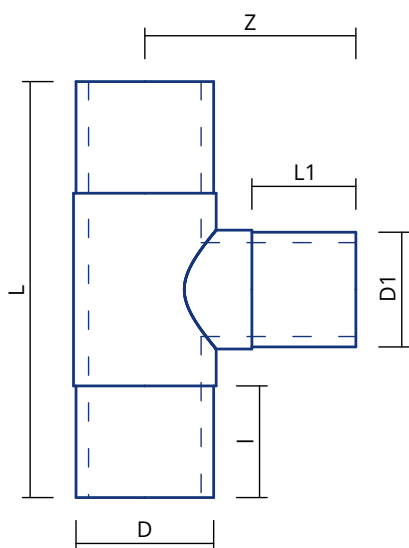

Размер D (mm)	PN	L (mm)	L1 (mm)	Z (mm)	I (mm)	Тегло (kg)	Материал
200-63	PN10	420	60	200	110	3.40	PEHD
200-63	PN16	420	60	200	110	4.75	PEHD
200-75	PN10	420	70	200	110	0.40	PEHD
200-75	PN16	420	70	200	110	4.80	PEHD
200-90	PN10	420	85	220	110	3.70	PEHD
200-90	PN16	420	85	220	110	5.05	PEHD
200-110	PN10	420	80	215	110	3.80	PEHD
200-110	PN16	420	80	215	110	5.00	PEHD
200-125	PN10	420	100	230	110	3.55	PEHD
200-125	PN16	420	100	230	110	5.10	PEHD
200-160	PN10	420	100	230	110	4.05	PEHD
200-160	PN16	420	100	230	110	5.40	PEHD
200-180	PN16	420	110	250	110	7.60	PEHD
225-90	PN10	425	80	225	115	4.35	PEHD
225-90	PN16	425	80	225	115	6.20	PEHD
225-110	PN10	425	80	225	115	4.31	PEHD
225-110	PN16	425	80	225	115	6.25	PEHD
225-125	PN10	425	100	240	115	4.45	PEHD
225-125	PN16	425	100	240	115	6.00	PEHD
225-160	PN10	425	100	240	115	4.85	PEHD
225-160	PN16	425	100	240	115	6.60	PEHD
250-50	PN16	455	65	230	130	7.70	PEHD
250-63	PN16	455	65	230	130	7.75	PEHD
250-90	PN10	455	80	245	130	5.90	PEHD
250-90	PN16	455	80	245	130	7.95	PEHD
250-110	PN10	455	80	240	130	5.47	PEHD
250-110	PN16	455	80	240	130	8.00	PEHD
250-125	PN10	455	95	260	130	5.80	PEHD
250-125	PN16	455	95	260	130	8.25	PEHD
250-140	PN10	455	95	240	130	5.53	PEHD
250-160	PN10	455	100	250	130	6.15	PEHD
250-160	PN16	455	100	250	130	8.20	PEHD
250-200	PN10	555	100	255	130	8.31	PEHD
250-200	PN16	555	100	255	130	10.44	PEHD
280-110	PN10	460	85	250	150	8.08	PEHD
280-110	PN16	460	85	250	150	10.87	PEHD
280-160	PN10	460	90	260	150	10.06	PEHD
280-160	PN16	460	90	260	150	11.14	PEHD
280-200	PN10	590	115	275	135	10.18	PEHD
280-200	PN16	590	115	275	135	13.58	PEHD
315-90	PN10	510	80	265	140	9.76	PEHD
315-90	PN16	510	80	265	140	13.90	PEHD
315-110	PN10	510	80	265	140	10.35	PEHD
315-110	PN16	510	80	265	140	13.91	PEHD
315-140	PN10	510	95	285	140	10.20	PEHD
315-160	PN10	510	100	290	140	10.15	PEHD
315-160	PN16	510	100	290	140	14.65	PEHD
315-200	PN10	510	120	305	140	10.60	PEHD
315-200	PN16	510	120	305	140	14.75	PEHD
315-225	PN10	670	110	315	145	14.60	PEHD
315-250	PN10	665	125	315	145	15.49	PEHD
315-250	PN16	665	125	315	145	20.07	PEHD
355-110	PN10	430	85	290	130	10.90	PEHD
355-110	PN16	430	85	290	130	14.84	PEHD
355-160	PN10	430	100	300	130	11.33	PEHD
355-160	PN16	430	100	300	130	15.49	PEHD
355-250	PN10	580	150	325	120	15.50	PEHD
355-250	PN16	580	150	325	120	21.60	PEHD
400-110	PN10	485	85	315	155	16.33	PEHD
400-110	PN16	485	85	315	155	21.79	PEHD
400-160	PN10	485	100	330	145	16.53	PEHD
400-160	PN16	485	100	330	145	22.83	PEHD
400-250	PN10	630	150	350	160	20.50	PEHD
400-250	PN16	630	150	350	160	28.70	PEHD
400-315	PN10	790	135	370	180	28.59	PEHD
400-315	PN16	790	135	370	180	38.00	PEHD



Съдържанието и информацията в тази брошура са предназначени само за общи търговски цели и никога не бива да разчита на тях като на пълни и точни. В частност, тази брошура не може да замени надлежния експертен съвет касателно характеристиките на продуктите, тяхната употреба, пригодността им за конкретните цели или правилния начин за тяхната обработка. Всички приноси и илюстрации в брошурата са предмет на авторско право. Освен ако изрично не е посочено друго, повторение на съдържанието не е позволено. Фотокопия от брошурата може да се ползват само за частни и нетърговски цели. Копирането и разпространяването на брошурата за професионални цели е строго забранено. Отказ от отговорност: Pipelife е съставил настоящата брошура добросъвестно. Pipelife не носи отговорност за щети, понесени от трети лица в резултат от или във връзка с това че са разчитали на съдържанието или информацията от брошурата. Това ограничение в отговорността важи за всички и всякакъв вид загуби или щети, включително, но не само преки или косвени щети, произтичащи или наказателни щети, излишни разходи, пропуснати ползи или загуба на дейност.

Производство / Централен склад  
Ботевград; 2140, п.к. 65, Ул. „Индустиална“ 3  
E office.bg@pipelife.com, [pipelife.bg](http://pipelife.bg)

**PIPELIFE**   
always part of your life