

AQUALINE RC, ROBUST RC

PE100RC PRESSURE PIPES FOR UNDERGROUND
INSTALLATION WITHOUT A SANDING PAD AND
SINK IN THE AREA AROUND THE PIPE.
PROTECTED AGAINST SLOW CRACK GROWTH.

CONTENTS

1	HISTORY OF POLYETHYLENE	3
2.	WHAT IS RC?	3
3.	WHY RC?	5
4.	MAIN TYPES OF PRESSURE POLYETHYLENE PIPES PROTECTED AGAINST SLOW CRACK GROWTH.....	5
5.	WHAT ARE FEATURES OF THE PIPES PROTECTED AGAINST SLOW GROWTH OF CRACKS OF PIPELIFE BULGARIA	6
6.	TECHNICAL CHARACTERISTICS OF POLYETHYLENE	9
7.	CHEMICAL CHARACTERISTICS OF POLYETHYLENE	10
8.	GRANULATE FOR THE PRODUCTION OF PRESSURE PIPES OF PE100RC	11
9.	DIMENSIONS OF POLYETHYLENE PRESSURE PIPES	12
10.	POLYETHYLENE PIPES PE 100RC AQUALINE RC BDS EN12201-2	12
11.	POLYETHYLENE PIPES PE 100RC AQUALINE RC BDS EN12201-2. PRODUCTION IN BOTEVGRAD	13
12.	POLYETHYLENE PIPES ROBUST RC BDS EN12201-2	15
13.	POLYETHYLENE PRESSURE PIPES: DIAGRAM OF FRICTION LOSSES	17
14.	DIAGRAM OF THE COEFFICIENT FOR CORRECTION OF FRICTION LOSSES IN POLYETHYLENE PRESSURE PIPES	18
15.	HIGH DENSITY POLYETHYLENE PIPES: RATIO OF PRESSURE LIMITS TO PERMISSIBLE TEMPERATURES UNDER DIFFERENT CONDITIONS OF CONTINUOUS USE	18
16.	HIGH DENSITY POLYETHYLENE PIPES: DIAGRAM OF THE DEPLOYMENT OF SUPPORTS	19
17.	HIGH DENSITY POLYETHYLENE PIPES: ADJUSTMENT COEFFICIENT FOR DEPLOYMENT OF SUPPORTS	20
18.	CALCULATION FOR VARIATIONS OF BURIED POLYETHYLENE PIPES	20
19.	TENSILE STRENGTH OF PIPES UNDER EXTERNAL HYDROSTATIC PRESSURE	21
20.	TRANSPORT AND STORAGE OF POLYETHYLENE PIPES	27
21.	INSTALLATION OF POLYETHYLENE PIPES	27
22.	JOINING OF POLYETHYLENE PIPES	28
23.	BUTT WELDING: WELDING STRENGTH	32
24.	BUTT WELDING: HEATING AND COOLING TIMES	33
25.	BASIC TESTS OF PRESSURE POLYETHYLENE PIPES ACCORDING TO BDS EN 12201-2	34
26.	RESISTANCE CERTIFICATION OF POLYETHYLENE PRESSURE PIPES	36
27.	APPLICATION OF AQUALINE RC AND ROBUST RC	40

1 HISTORY OF POLYETHYLENE

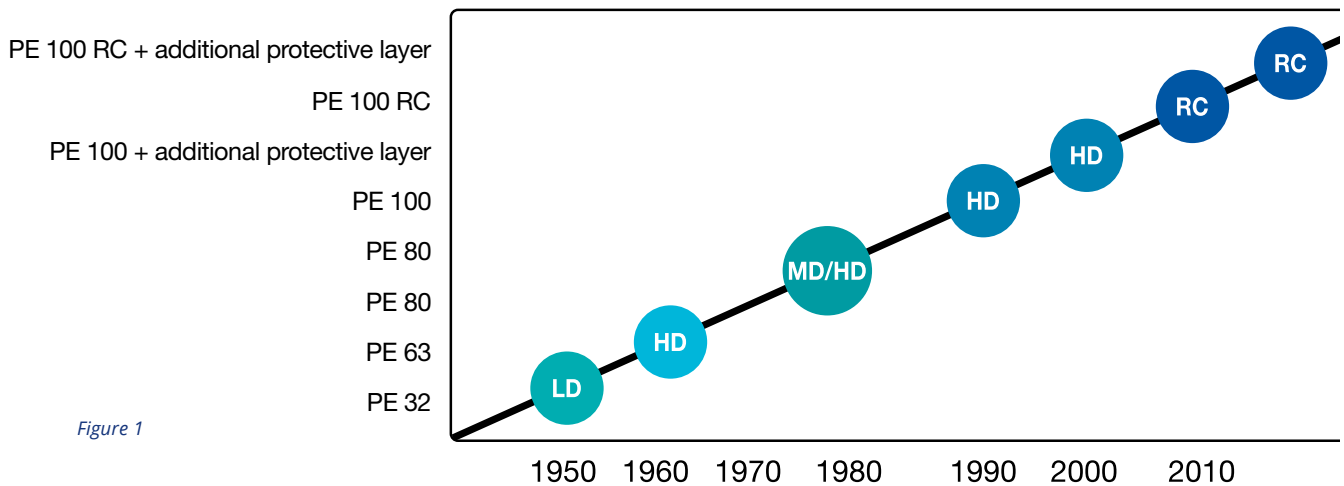

Figure 1

The graph above shows a brief historical overview of the development of polyethylene designed for the production of pressure water systems. Progress in polyethylene has been mainly to increase its density and strength. From low density, through medium density to high density and PE32, PE63, PE80 to PE100, respectively.

The PE 63, PE 80, and PE 100 abbreviations numbers divided by 10 actually show the minimum required strength (MRS) of the material in MPa, namely 6.3 MPa, 8.0 MPa, 10.0 MPa.

The minimum required polyethylene strength indicates what internal ductility the pipe needs to withstand without rupturing as a result of the pressure of the water (fluid) in it.

The increase in MRS of polyethylene has led to the possibility of producing thinner walls of stronger materials, which in turn increases the light section of the pipes and improves their hydraulic conductivity, as well as the ability to produce tubes withstanding higher pressures.

To date, the most modern and widely used material for the production of pressure polyethylene pipes is PE100.

The years of operation experience have shown that besides the durability of polyethylene to the pressure of the fluid in the pipes, the durability of slow cracking as a result of the formation of small holes on the surface from scratches and concentrated loads of larger and sharp objects in the backfill on the pipe is also of utmost importance.

The initial step in this direction was to put an additional protective layer on the PE100 pipes. PE100 pipes with an additional protective layer appeared. This protective layer is not extruded together with the tube and is not fused to it.

The most recent step to date in the development of polyethylene is the production of resistant to crack polyethylene („RC”), the so- PE100RC. PE100RC pipes similar to PE100 pipes can be with or without an additional protective layer.

Service Life

To demonstrate the long-lasting performance of polyolefin (polyethylene and polypropylene) pipes, a study was conducted by Teppfa (European Association of Plastic Pipe and Fittings Manufacturers) in collaboration with Borealis and LyondellBasell. The purpose of the study was to provide sufficient validated data in order to declare the expected duration of at least 100 years of operation of pipes manufactured according to the standards. In the course of the study, their thermal-oxidative decay, maximum

allowable stress, long-term behavior at constant tension and temperature influence were investigated. For the study, new tubes and those in use for over 40 years have been used. All of these methods were implemented in accordance with valid international standards (ISO) and the accumulated knowledge of polymer materials science. The results have shown that the lifetime of polyolefin piping systems is at least 100 years provided that the materials, products and installation practices meet the relevant requirements.

2 WHAT IS RC?

The newest and safest grade high density polyethylene for the production of pressure polyethylene pipes is the PE 100 RC. Practically, this is PE 100 with added increased resistance against a slow rise of cracks on the surface of the pipe. The abbreviation RC stands for Resistant to Crack - crack-resistant.

From the diagram below, it is clear that practically, this

is the same material with the only distinctive feature - resistance to slow crack growth. This means that in all other respects, as the bonding, laying, hydraulic conductivity and static resistance, the two materials are identical. Thus, practically, the end-user receives a new type of value-added material, but without unnecessary complications in installation, hydraulic and static calculations.

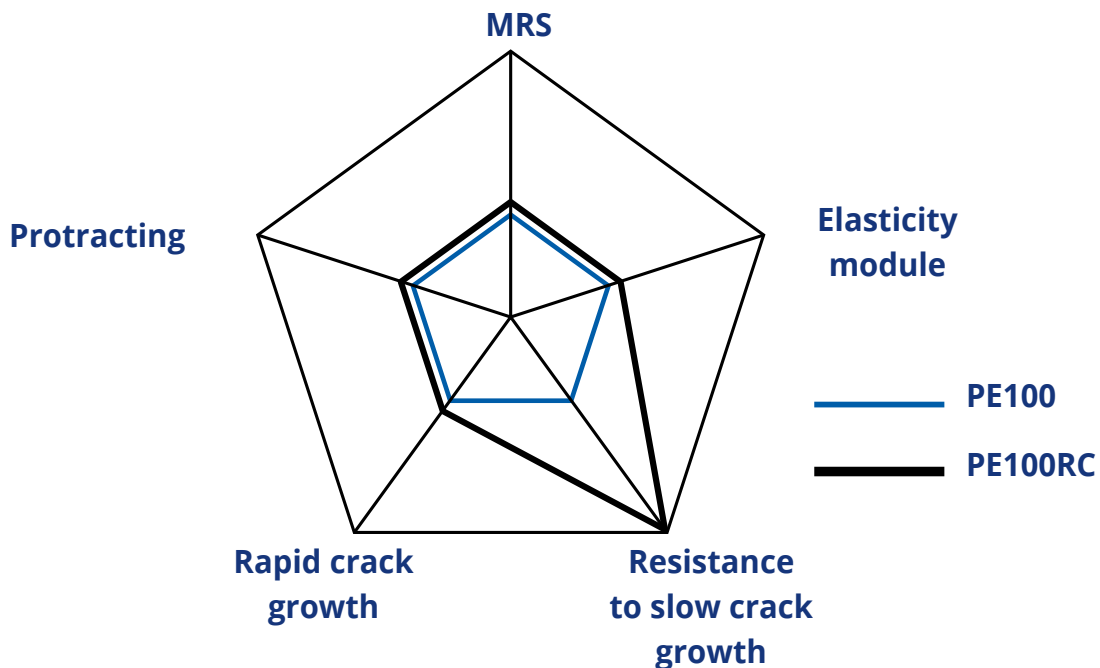

Figure 2

3 WHY RC?

Years of installation and operation experience have shown that, besides the strength of the materials, it is very important for the durability of pipelines to preserve their structural integrity. The formation of scratches when laying the pipes and their increase to cracks over time reduces the working section of the pipe wall, which results in increased stresses in the material. In these areas of increased stress, most often a breakthrough occurs in the structure of the pipe and hence a water loss failure.

The reasons for cracking by the trench laying of the pipes are most often due to non-compliance with the requirement for sanding in the area around the pipe to consist of sand, as well as its mixing with larger and

sharp particles and pebbles. In the case of trenchless laying, the pipe pulled underground may encounter sharp objects and stones along the way, which can cause structural changes on the surface. The presence of sharp stones in contact with the surface of the pipe and the pressure of the water in the pipeline creates conditions for a constant concentrated load, whereby the likelihood of cracking is increased.

Pipes made of PE 100 RC mainly guarantee less possibility of formation of cracks, and especially that if a crack is formed on the surface of the pipe, it will grow much more slowly with equal other conditions compared to a pipe made of PE 100.

4 MAIN TYPES OF PRESSURE POLYETHYLENE PIPES PROTECTED AGAINST SLOW CRACK GROWTH

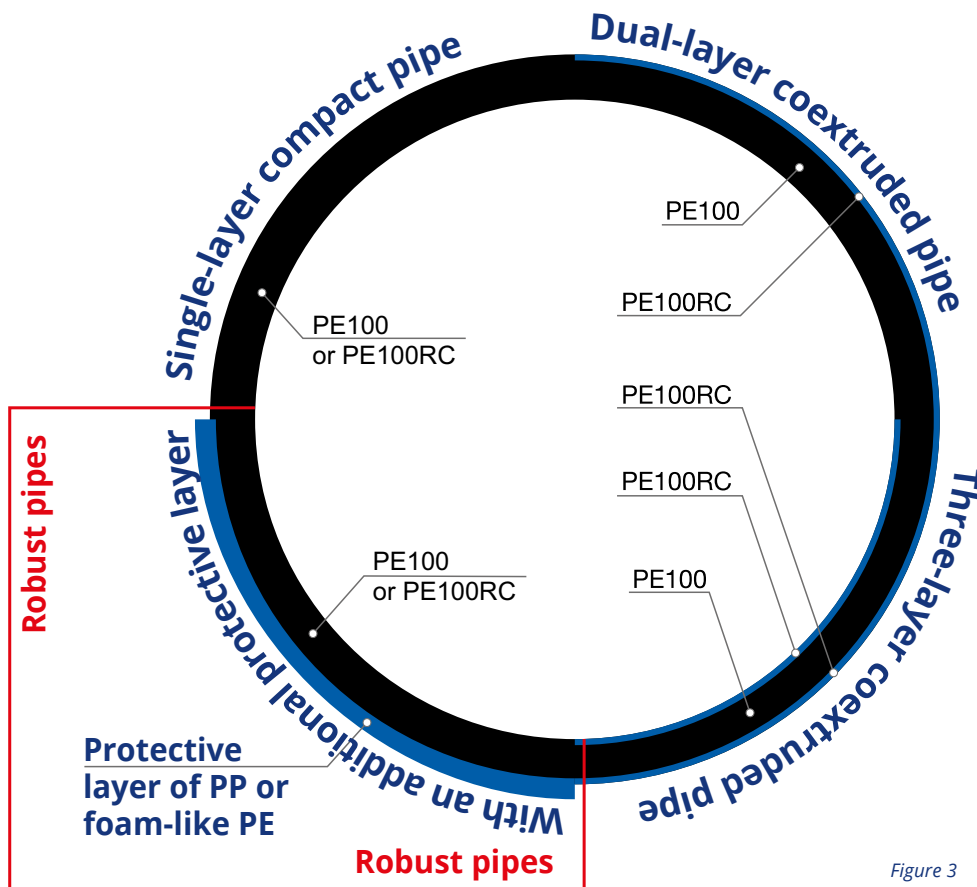

Figure 3

Several basic types of pipes associated with protection against slow crack growth are offered on the market.

Classification of pipes according to PAS 1075	
Type 1:	PE 100 RC thick-walled pipe PE 100R C single-layer thick-walled pipes according to DIN 8074 / ISO 4065.
Type 2:	Pipes with size-integrated PE 100 RC protective layer <ul style="list-style-type: none"> • Dual-layer pipes with a size-integrated protective layer are made of PE100 or PE100RC and have an internal co-extruded PE100RC protective layer. • Three-layer pipes with integrated protection layers are made of PE100 or PE100RC and have an inner and outer co-extruded protective layer of PE100RC <p>The coextruded layers are inextricably interconnected by melting in one unit. The inner layer is integrated as a functional layer of PE100RC in the wall construction.</p>
Type 3:	Pipes with dimensions according to DIN 8074 / ISO 4065 with external surface-added protective coating Pipes with dimensions according to DIN 8074 with external protective coating are made of PE100RC main pipe and polypropylene protective coating. The minimum thickness of the protective coating is 0.8 mm. The minimum thickness of the protective coating depends on the size and, in larger sizes, it is greater due to the higher loads. The strength of the coupling between the main tube and the protective coating must be so strong as to withstand the forces of slipping. An integrated detector wire could be integrated in the pipes.

5 WHAT ARE FEATURES OF THE PIPES PROTECTED AGAINST SLOW GROWTH OF CRACKS OF PIPELIFE BULGARIA

5.1 AQUALINE RC



Single-layer pressure pipe of PE100RC

Figure 5



Figure 6

5.2 ROBUST RC

Single layer compact pipes with an additional protective layer of polypropylene (PP), with the possibility of the integrated detector wire.

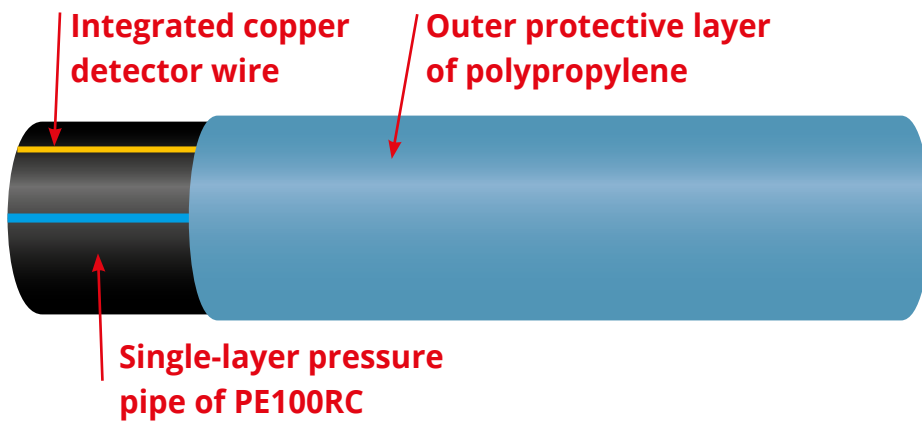

Figure 9

- The protective layer of compact PP provides extra security against formation of holes and hence cracks during storage, transport, unloading, and laying.
- Built-in detector wire saves time to run an additional detector strip over the tube.
- The insertion of an additional detector tape is possible only in the case of trench laying with reverse backfill. In the case of trenchless laying, the pipes will not have a detector strip and it will be harder to locate.
- Ideal for laying without a sand bed.
- Ideal solution for all types of trenchless technology.
- Fast and easy installation.

The tubes with the trademark **Aqualine RC** are single layer compact tubes entirely made of PE 100 RC. They show an extremely high resistance against slow cracking and high point loading. This to a big extent determines a longer service life with equal other conditions compared to pipes made only from PE 100 or so-called multilayer co-extruded tubes in which only a portion of the cross section, most often the outer surface is of PE 100 RC, and the rest is of PE 100.

On both PE 100 and PE 100 RC scratches (holes) can be formed due to the impact of sharp objects on

the outer surface of the pipe. Subsequently, these scratches can grow into cracks. When the entire wall section of the pipe is of PE 100 RC, even if a crack is formed, the pipe is much safer to protect as the crack growth will be much slower. For multilayer pipes with an outer (and / or inner) layer of PE 100RC and an intermediate (PE) layer of PE 100, the original scratch could have cut the entire PE 100 RC layer and could have reached the layer of PE 100. Then the crack growth will accelerate and the multilayer tube will be much more vulnerable than the single-layer compact pipe.

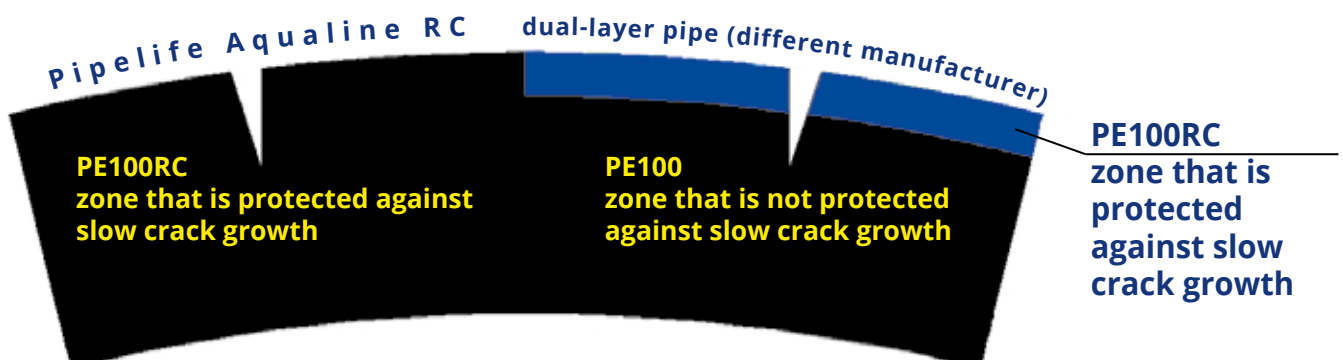

Figure 11

Another major cause of crack formation is the concentration of internal stresses in the inner surface of the pipe due to a point load on the outer surface. Due to the concentration of stresses, a hole can be formed, and it subsequently becomes a crack. Here again, the security advantage is for single-layer PE100RC pipes, in which the entire pipe section is PE

100 RC, whereas for multi-layer pipes with an outer PE 100 RC layer and an intermediate (inner) PE 100 layer, if the original crack reaches the PE 100 layer, the crack growth will accelerate and the multilayer pipe will be much more vulnerable than the single-layer compact pipe.

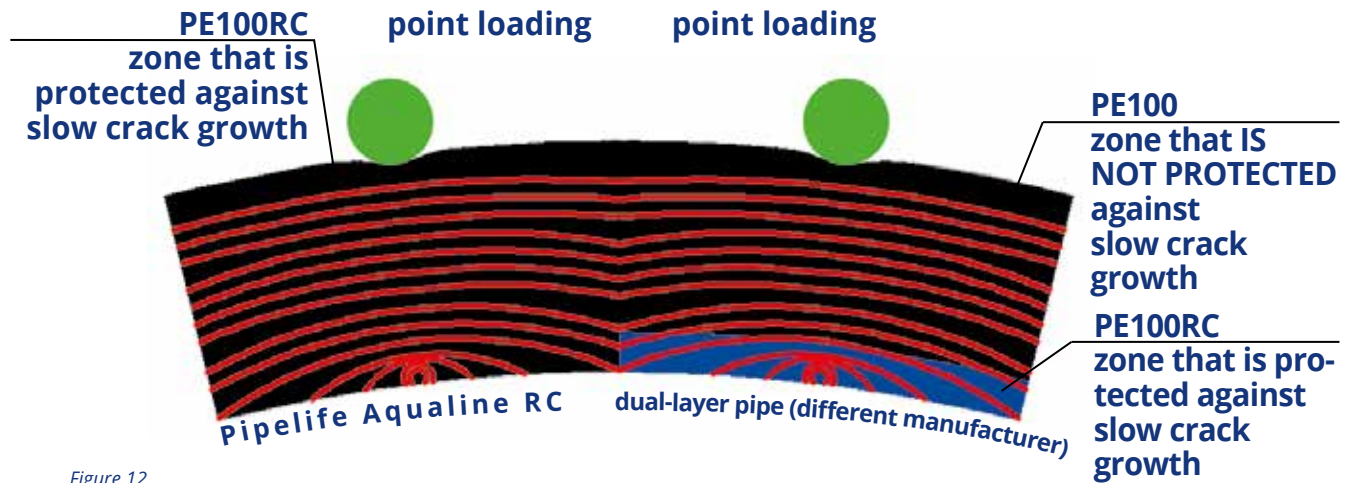

Figure 12

Single-layer compact pipe of PE100RC	Multilayer coextruded pipe of PE100RC and PE10
The entire pipe section is made of PE100RC.	Only one section of the pipe section is of PE100RC. Typically, an outer and / or an inner layer. The intermediate layer is PE100.
The whole section of the pipe is protected against the growth and spread of cracks.	Only a portion of the pipe section (the outer and / or inner layer) is protected against growth and spreading of cracks. If the protective layer of PE100RC is ruptured so as to reach the layer of PE100, the multi-layer pipe loses its security against the growth and spreading of cracks.
<p>The difference in raw material prices for PE100 and PE100RC is becoming smaller compared to the additional security that PE100RC has against crack growth. This to a large extent neglects the savings at the expense of the security that comes in the case of PE100 and PE100RC multilayer pipes.</p>	
<p>Single-layer compact pipes of PE100RC - the better and safer solution!</p>	

Табл. 1

6 POLYETHYLENE TECHNICAL PROPERTIES

	Specification	Units	High density PE MRS 6.3	Middle density PE MRS 8	High polymer PE MRS 10
Mechanical properties					
Density	ASTM D 792	Kg/m ³	955	949	960
Melting index (load 5 kg)	ISO 1133	g/10min	0.48	0.85	0.45
Elasticity module (50 mm/min, 23°C)	ISO 527	MPa	1150	650	1400
Tensile strength (50 mm/min, 23°C DIN)	DIN 53455	MPa	39	28	38
Yield strength (50 mm/min, 23°C DIN)	DIN 53455	MPa	25	20	25
Elongation at break (50 mm/min, 23°C DIN)	DIN 53455	%	>500	>600	>600
Resistance to cracking due to environment load	Bell Telephone Test F50	h	>500	>1000	>1000
Physical properties					
Softening (1Kg)	DIN 53460	°C	128	121	127
Heat conductivity	DIN 52612	W/m·K	0.4	0.38	0.38
Specific heat	Calorimetric	Kj/Kg·K	1.8	3.4	1.9
Coefficient of thermal expansion	ASTM D 696	K-1	1.3·10 ⁻⁴	1.3·10 ⁻⁴	1.3·10 ⁻⁴
Brittleness temperature (Tg)	ASTM D 746	°C	<-100	<-100	<-100
Electrical properties					
Dielectric constant	DIN 53483		2.6	2.6	2.6
Dielectric strength	DIN 53481	KV/cm	2.2·10 ²	2.2·10 ²	2.2·10 ²
Special volume resistivity	DIN 53482	Ω.cm	≥10 ¹⁷	≥10 ¹⁷	≥10 ¹⁷
Surface resistivity	DIN 53482	Ω	≥10 ¹⁴	≥10 ¹⁴	≥10 ¹⁴

The above values are indicative.

According to ISO 9080, the minimum required strength (MRS) is the value of long-term hydrostatic strength with a lower limit of confidence of 97.5% shown by one pipe after 50 years of constant work at 20°C.

7 POLYETHYLENE CHEMICAL PROPERTIES

CHEMICALS	CHEMICAL CONCENTRATION*	LDPE HDPE				CHEMICALS	CHEMICAL CONCENTRATION*	LDPE HDPE			
		TEMPERATURE**						TEMPERATURE**			
		20°C	60°C	20°C	60°C			20°C	60°C	20°C	60°C
Gasses, containing:	-	-	-	-	Nitric acid	w.s. 25%	1	1	1	1	
Carbon dioxide		1	1	1	1	Nitric acid	w.s. 50%	2	3	2	3
Sulphur dioxide	l.c.	1	1	1	1	Nitrobenzene		2	3	1	2
Sulphuric acid		1	1	1	1	Nitric vapours		1	-	1	1
Carbon oxide		1	1	1	1	Ozone		2	3	2	3
Nitric vapours	admixtures	1	1	1	1	Acetic acid	w.s. 10%	1	1	1	1
Fluorine hydrogen	admixtures	1	1	1	1	Acetic acid	w.s. 100%	2	3	1	2
Salt		1	1	1	1	Acetic etileter		2	3	2	3
Ethereal oils		-	-	2	2	Acetic anhydride		2	-	1	2
Ethyl alcohol	96%	1-2	3	1	1	Vinegar		-	-	1	1
Acetone	100%	2	3	3	2	Mineral oils		2	3	1	2
Acetone	admixtures	1	1	1	1	Urea		1	1	1	1
Saturated salt solution		1	1	1	1	Petroleum on paraffinic base		1	1	1	1
Gaseous ammonia		1	1	1	1	Petroleum ether		2	3	1	2
Ammonia solution	100%	1	-	1	1	Petroleum		2	3	1	2
Starch		1	1	1	1	Diesel fuel		2	3	1	2
Sodium carbon		1	1	1	1	Propanol		1	1	1	1
Washing agents		1	1	1	1	Propylene glycol		1	1	1	1
Petrol		2	3	1	2	Sodium silicate		1	1	1	1
Benzene		3	3	2	2	Stearic acid		1	3	1	2
Borax		1	1	1	1	Alum		1	1	1	1
Potassium borate	w.s. 1%	1	1	1	1	Tannin	w.s. 10%	1	1	1	1
Boron acid		1	1	1	1	Turpentine		2	3	2	3
Butanol		1	1	1	1	Carbon tetrachloride		3	3	3	3
Potassium bromate		1	1	1	1	Tetrachloride		3	3	3	3
Lactic acid		1	1	1	1	Toluene		3	3	3	3
Glycerin		1	1	1	1	Ferric chloride		1	1	1	1
Glucose		-	-	-	-	Trichloroethylene		3	3	3	3
Dextrine	w.s. 18%	1	-	1	1	Tartaric acid		1	1	1	1
Diethyl ether		3	3	2	2	Mercury		1	1	1	1
Carbon sulphide		3	-	2	-	Brominenytrogen acid	50%	1	1	1	1
Sodium bisulfate	t.w.s.	1	1	1	1	Nytrogen		1	1	1	1
Carbon dioxide		1	1	1	1	Hydrosulphuric acid		1	1	1	1
Sulphur dioxide		1	1	1	1	Hydrochloric acid	w.s. 36%	1	2	1	1
Dichlorethan		2	2	2	2	Hydrochloric acid (dry gas or liquid)		1	1	1	1
Dichlorethylene		3	3	3	3	Potassium permanganate	s.w.s.	1	2	1	2
Potassium dichromate	w.s. 40%	1	1	1	1	Hydrogen peroxide	w.s. 30%	1	1	1	1
Animal and vegetable oils		-	1	1	2	Hydrogen peroxide	w.s. 90%	1	3	1	3
Transformer oils		-	1	2	1	Perchloric acid	w.s. 20%	1	-	1	1
Sulphuric acids of different metals		1	1	1	1	Calcium nitrate		1	1	1	1
Sulphuric acid	w.s. 40%	1	1	1	1	Calcium hypochlorite		2	2	1	1
Sulphuric acid	98%	2	3	2	3	Phenol		2	3	1	2
Sulphuric acid	with vapours	3	3	3	3	Formaldehyde	w.s. 40%	1	1	1	1
Sulphurous acid		1	1	1	1	Phosphoric acid	w.s. 25%	1	1	1	1
Potassium		1	1	1	1	Phosphoric acid	w.s. 50%	1	1	1	1
Sodium		1	1	1	1	Phosphoric acid	w.s. 85%	1	2	1	2
Ketones		2	3	1	2	Fixer emulsion		1	1	1	-
Citric acid		1	1	1	1	Chlorides of dry gasses		2	3	3	3
Acids, containing fats		1	3	1	2	Chloroacetic acid		3	3	1	1
Methanol		1	2	1	1	Perchloric acids of different metals		1	1	1	1
Molasses		-	-	1	1	Methyl chloride		3	3	2	2
Beer		1	1	1	1	Sodium chloride	w.s. 50%	2	3	1	1
Formic acid		1	1	1	1	Chloroform		3	3	3	3
Naphtha		1	2	1	2	Chromic acid	w.s. 50%	3	3	1	3
Naphthalene		1	2	1	2	Fruit juices		1	1	1	1
Nitrogen salts of different metals		1	1	1	1						

* Without indication = pure substance **Without indication = unregistered

1 = Good resistance

2 = Moderate resistance

3 = Not recommended

w.s. = water solution with concentration higher than 10%, but unsaturated

l.w.s. = water solution low concentration (under 10%)

s.s. = saturated solution

l.c. = low concentration

h.c. = high concentration

% = weight percentage

This information concerns only ordinary chemical resistance. When giving an account of other factors like resistance to cracking due to load, conductivity and others, it is necessary to put to specific tests for compatibility.

8 COMPOUND FOR PRODUCTION OF PE100 PRESSURE PIPES

Compound from which polyethylene water pipes are being produced must be preliminary colored in the color of the final product according to the production standard BDS EN 12201-1. If pipes must be black compound is black. If they must be blue compound is blue and so on. Standard BDS EN12201-1 **FORBIDS** the usage of colorless (natural) PE compound in production of polyethylene water pipes.



Only preliminary colored compound guarantees a homogeneous structure of the produced pipes, good longtime pressure resistance and good elasticity of the material.

The usage of a colorless compound and its sequential coloring during the production causes bad homogeneity of the material, which can be seen only with microscope:

Good homogeneous structure of a pipe produced from preliminary colored compound.

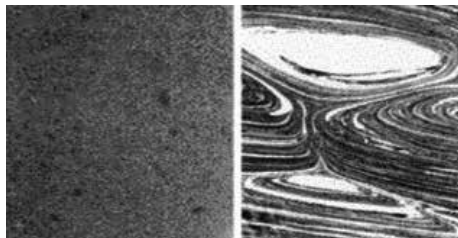

Bad heterogeneous structure of a pipe produced from preliminary colored compound.

The quality of the PE pipe is deteriorated due to bad homogeneity. This leads both to substantial reduction of the operational life of the pipe and to eventual bursting of the pipe. Such pipes cannot bear the laboratory tests for internal hydrostatic pressure and tensile stress, which basically depend on the material that is used for the production of the pipe.

In some rare cases mixing of the pigment and the compound during the extrusion is so bad that separated layers in the pipe cross-section could be noticed with the naked eye.



Some producers buy colorless compound and after that they color it during the extrusion because in this way they save money (the colorless compound is cheaper than the preliminary colored compound). They gain lower price by worsening quality and safety.

Pipelife Bulgaria EOOD is producing its own polyethylene pipes entirely from **VERGIN AND CERTIFIED COMPOUND** from established manufacturers of the international market like "Sabic", "Borealis", "Basell" and "Ineos". These manufacturers guarantee **CONSTANT** high quality of their compound. Each delivery of polyethylene compound in the factory in Botevgrad comes with a Quality Certificate issued by the manufacturer of this compound. Our laboratory staff takes 50 grams of polyethylene compound and tests a certain part of that quantity and the rest part of the sample is conserved for six months.



The material for production of polyethylene pipes for water and gas is preliminary colored high density polyethylene (PE100). The PE water pipes are produced in black color with blue stripes.

9 POLYETHYLENE PRESSURE PIPES DIMENSIONS

10 POLYETHYLENE PIPES PE 100RC AQUALINE RC BDS EN12201-2

Outer diameter (mm)		6 BAR (SDR 26)		10 BAR (SDR 17)		12.5 BAR (SDR13.6)		16 BAR (SDR 11)		20 BAR (SDR 9)		25 BAR (SDR 7,4)		32 BAR (SDR 6)					
		Wall thickness (mm)	Weight (kg/m)	Wall thickness (mm)	Weight (kg/m)	Wall thickness (mm)	Weight (kg/m)	Wall thickness (mm)	Weight (kg/m)	Wall thickness (mm)	Weight (kg/m)	Wall thickness (mm)	Weight (kg/m)	Wall thickness (mm)	Weight (kg/m)				
min	max	min	max	min	max	min	max	min	max	min	max	min	max	min	max				
16	16.3																		
20	20.3							2.0	2.3	2.7	0.116	2.3	2.7	3.0	3.4	0.162	3.4	3.9	0.180
25	25.3			2.0	2.3	0.148	2.3	2.7	0.170	3.0	3.4	0.210	3.5	4.0	4.2	0.240	4.2	4.8	0.278
32	32.3			2.0	2.3	0.193	2.4	2.8	0.230	3.0	3.4	0.327	4.4	5.0	5.4	0.387	5.4	6.1	0.455
40	40.4			2.4	2.8	0.293	3.0	3.5	0.360	3.7	4.2	0.429	4.5	5.1	5.5	0.509	6.2	6.7	0.704
50	50.5	2.0	2.3	3.0	3.4	0.451	3.7	4.2	0.548	4.6	5.2	0.666	5.6	6.2	6.9	0.790	8.7	9.3	1.09
63	63.6	2.5	2.9	3.8	4.3	0.720	4.7	5.3	0.874	5.8	6.5	1.05	7.1	8.0	8.6	1.26	9.6	10.5	1.74
75	75.7	2.9	3.3	4.5	5.1	1.01	5.6	6.3	1.24	6.8	7.6	1.47	8.4	9.4	10.3	1.77	11.5	12.5	2.46
90	90.9	3.5	4.0	5.4	6.1	1.46	6.7	7.5	1.78	8.2	9.2	2.13	10.1	11.3	12.3	2.56	13.7	15.0	3.54
110	110.0	4.2	4.8	6.6	7.4	2.17	8.1	9.1	2.63	10.0	11.1	3.16	12.3	13.7	15.1	3.80	16.8	18.3	5.28
125	126.2	4.8	5.4	7.4	8.3	2.77	9.2	10.3	3.39	11.4	12.7	4.10	14.0	15.6	17.1	4.92	19.0	20.8	6.81
140	141.3	5.4	6.1	8.3	9.3	3.48	10.3	11.5	4.24	12.7	14.1	5.11	15.7	17.4	19.2	6.16	21.3	23.3	8.54
160	161.5	6.2	7.0	9.5	10.6	4.54	11.8	13.1	5.54	14.6	16.2	6.71	17.9	19.8	21.9	8.02	24.2	26.6	11.1
180	181.7	6.9	7.7	10.7	11.9	5.75	13.3	14.8	7.03	16.4	18.2	8.49	20.1	22.3	24.6	10.1	27.2	29.9	14.1
200	201.8	7.7	8.6	11.9	13.2	7.09	14.7	16.3	8.62	18.2	20.2	10.5	22.4	24.8	27.4	12.5	30.3	33.2	17.4
225	227.1	8.6	9.6	13.4	14.9	8.99	16.6	18.4	10.9	20.5	22.7	13.2	25.2	27.9	30.8	15.9	34.0	37.4	22.0
250	252.3	9.6	10.7	14.8	16.4	11.0	18.4	20.4	13.5	22.7	25.1	16.3	27.9	30.8	34.2	19.5	37.8	41.5	27.1
280	282.6	10.7	11.9	16.6	18.4	13.8	20.6	22.8	16.9	25.4	28.1	20.4	31.3	34.6	38.3	24.5	42.3	46.5	34.1
315	317.9	12.1	13.5	18.7	20.7	17.5	23.2	25.7	21.4	28.6	31.6	25.9	35.2	38.9	43.1	31.0	47.6	52.3	43.1
355	358.2	13.6	15.1	21.1	23.4	22.3	26.1	28.9	27.2	32.2	35.6	32.8	39.7	43.8	48.5	39.4	53.5	59.0	54.8
400	403.6	15.3	17.0	23.7	26.2	28.2	29.4	32.5	34.4	36.3	40.1	41.7	44.7	49.3	54.7	50.0	60.3	65.0	
450	453.8	17.2	19.1	26.7	29.5	35.7	33.1	36.6	43.6	40.9	45.1	52.8	50.3	55.5	63.3	61.5	67.8	75.1	
500	504.0	19.1	21.2	29.7	32.8	44.2	36.8	40.6	53.8	45.4	50.1	65.1	55.8	61.5	78.0				
560	564.3	21.4	23.7	33.2	36.7	55.3	41.2	45.5	67.5	50.8	56.0	81.5							
630	634.6	24.1	26.7	37.4	41.3	70.1	46.3	51.1	85.3	57.2	63.1	103.3							
710	714.9	27.2	30.1	42.1	46.5	88.9	52.2	57.6	108.4										
800	805.0	30.6	33.8	47.4	52.3	112.7	58.8	64.8	137.5										
900	905.0	34.4	38.3	53.3	58.8	142.6													
1000	1005.0	38.2	42.2	59.3	65.4	176.2													
1200	1206.0	45.9	50.6	167.5															

11 POLYETHYLENE PIPES AQUALINE RC PE100RC BDS EN12201-2 BOTEVGRAD PRODUCTION

DN [mm]	Wall Thickness [mm]	PN [bar]	SDR	Bars/rolls	*PACKAGING				Designation in project
					No of pipes / pallet	Pallets / truck	No of pipes / truck	Meters / truck	
50	2,0-2,3	6	26	100					PE100RC SDR26 DN50x2.0
50	2,0-2,4	6	26	12					
63	2,5-2,9	6	26	100					PE100RC SDR26 DN63x2.5
63	2,5-2,10	6	26	12	116	10	1 160	13 920	
75	2,9-3,3	6	26	100					PE100RC SDR26 DN75x2.9
75	2,9-3,3	6	26	12	102	8	816	9 792	
90	3,5-4,0	6	26	100					PE100RC SDR26 DN90x3.5
90	3,5-4,0	6	26	12	58	10	580	6 960	
110	4,2-4,8	6	26	12	48	8	384	4 608	PE100RC SDR26 DN110x4.2
125	4,8-5,4	6	26	12	43	8	344	4 128	PE100RC SDR26 DN125x4.8
140	5,4-6,1	6	26	12	38	6	228	2 736	PE100RC SDR26 DN140x5.4
160	6,2-7,0	6	26	12	33	6	198	2 376	PE100RC SDR26 DN160x6.2
180	6,9-7,7	6	26	12	17	8	136	1 632	PE100RC SDR26 DN180x6.9
200	7,7-8,6	6	26	12	14	8	112	1 344	PE100RC SDR26 DN200x7.7
225	8,6-9,6	6	26	12	14	6	84	1 008	PE100RC SDR26 DN225x8.6
250	9,6-10,7	6	26	12	11	6	66	792	PE100RC SDR26 DN250x9.6
280	10,7-11,9	6	26	12	7	8	56	672	PE100RC SDR26 DN280x10.7
315	12,1-13,5	6	26	12	3	12	36	432	PE100RC SDR26 DN315x12.1
355	13,6-15,1	6	26	12	3	12	36	432	PE100RC SDR26 DN355x13.6
400	15,3-17,0	6	26	12	3	10	30	360	PE100RC SDR26 DN400x15.3

DN [mm]	Wall Thickness [mm]	PN [bar]	SDR	Bars/rolls	*PACKAGING				Designation in project
					No of pipes / pallet	Pallets / truck	No of pipes / truck	Meters / truck	
32	2,0-2,3	10	17	100					PE100RC SDR17 DN32x2.0
40	2,4-2,8	10	17	100					PE100RC SDR17 DN40x2.4
50	3,0-3,4	10	17	100					PE100RC SDR17 DN50x3.0
50	3,0-3,4	10	17	12					
63	3,8-4,3	10	17	100					PE100RC SDR17 DN63x3.8
63	3,8-4,3	10	17	12	116	10	1 160	13 920	
75	4,5-5,1	10	17	100					PE100RC SDR17 DN75x4.5
75	4,5-5,1	10	17	12	102	8	816	9 792	PE100RC SDR17 DN75x4.5
90	5,4-6,1	10	17	100					PE100RC SDR17 DN90x5.4
90	5,4-6,1	10	17	12	58	10	580	6 960	PE100RC SDR17 DN90x5.4
110	6,6-7,4	10	17	12	48	8	384	4 608	PE100RC SDR17 DN110x6.6
125	7,4-8,3	10	17	12	43	8	344	4 128	PE100RC SDR17 DN125x7.4
140	8,3-9,3	10	17	12	38	6	228	2 736	PE100RC SDR17 DN140x8.3
160	9,5-10,6	10	17	12	33	6	198	2 376	PE100RC SDR17 DN160x9.5
180	10,7-11,9	10	17	12	17	8	136	1 632	PE100RC SDR17 DN180x10.7
200	11,9-13,2	10	17	12	14	8	112	1 344	PE100RC SDR17 DN200x11.9
225	13,4-14,9	10	17	12	14	6	84	1 008	PE100RC SDR17 DN225x13.4
250	14,8-16,4	10	17	12	11	6	66	792	PE100RC SDR17 DN250x14.8
280	16,6-18,4	10	17	12	7	8	56	672	PE100RC SDR17 DN280x16.6
315	18,7-20,7	10	17	12	3	12	36	432	PE100RC SDR17 DN315x18.7
355	21,1-23,4	10	17	12	3	12	36	432	PE100RC SDR17 DN355x21.1
400	23,7-26,2	10	17	12	3	10	30	360	PE100RC SDR17 DN400x23.7

DN [mm]	Wall Thickness [mm]	PN [bar]	SDR	Bars/rolls	*PACKAGING				Designation in project
					Nº of pipes / pallet	Pallets / truck	Nº of pipes / truck	Meters / truck	
20	2,0-2,3	16	11	100					PE100RC SDR11 DN20x2.0
25	2,0-2,3	16	11	100					PE100RC SDR11 DN25x2.3
32	3,0-3,4	16	11	100					PE100RC SDR11 DN32x3.0
40	3,7-4,2	16	11	100					PE100RC SDR11 DN40x3.7
50	4,6-5,2	16	11	100					PE100RC SDR11 DN50x4.6
50	4,6-5,2	16	11	12					
63	5,8-6,5	16	11	100					PE100RC SDR11 DN63x5.8
63	5,8-6,5	16	11	12	116	10	1 160	13 920	
75	6,8-7,6	16	11	100					PE100RC SDR11 DN75x6.8
75	6,8-7,6	16	11	12	102	8	816	9 792	PE100RC SDR11 DN75x6.8
90	8,2-9,2	16	11	100					PE100RC SDR11 DN90x8.2
90	8,2-9,2	16	11	12	58	10	580	6 960	PE100RC SDR11 DN90x8.2
110	10,0-11,1	16	11	12	48	8	384	4 608	PE100RC SDR11 DN110x10
125	11,4-12,7	16	11	12	43	8	344	4 128	PE100RC SDR11 DN125x11.4
140	12,7-14,1	16	11	12	38	6	228	2 736	PE100RC SDR11 DN140x12.7
160	14,6-16,2	16	11	12	33	6	198	2 376	PE100RC SDR11 DN160x14.6
180	16,4-18,2	16	11	12	17	8	136	1 632	PE100RC SDR11 DN180x16.4
200	18,2-20,2	16	11	12	14	8	112	1 344	PE100RC SDR11 DN200x18.2
225	20,5-22,7	16	11	12	14	6	84	1 008	PE100RC SDR11 DN225x20.5
250	22,7-25,1	16	11	12	11	6	66	792	PE100RC SDR11 DN250x22.7
280	25,4-28,1	16	11	12	7	8	56	672	PE100RC SDR11 DN280x25.4
315	28,6-31,6	16	11	12	3	12	36	432	PE100RC SDR11 DN315x28.6
355	32,2-35,6	16	11	12	3	12	36	432	PE100RC SDR11 DN355x32.2
400	36,3-40,1	16	11	12	3	10	30	360	PE100RC SDR11 DN400x36.3

DN [mm]	Wall Thickness [mm]	PN [bar]	SDR	Bars/rolls	*PACKAGING				Designation in project
					Nº of pipes / pallet	Pallets / truck	Nº of pipes / truck	Meters / truck	
110	12,3-13,7	20	9	12	48	8	384	4 608	PE100RC SDR11 DN110x12.3
160	17,9-19,8	20	9	12	33	6	198	2 376	PE100RC SDR11 DN160x17.9
200	22,4-24,8	20	9	12	14	8	112	1 344	PE100RC SDR11 DN200x22.4
250	27,9-30,8	20	9	12	11	6	66	792	PE100RC SDR11 DN250x27.9
315	35,2-38,9	20	9	12	3	12	36	432	PE100RC SDR11 DN315x35.2
355	39,7-43,8	20	9	12	3	12	36	432	PE100RC SDR11 DN355x39.7
400	44,7-49,3	20	9	12	3	10	30	360	PE100RC SDR11 DN400x44.7
110	15,1-16,8	25	7,4	12	48	8	384	4 608	PE100RC SDR11 DN110x15.1
160	21,9-24,2	25	7,4	12	33	6	198	2 376	PE100RC SDR11 DN160x21.9
200	27,4-30,3	25	7,4	12	14	8	112	1 344	PE100RC SDR11 DN200x27.4
250	34,2-37,8	25	7,4	12	11	6	66	792	PE100RC SDR11 DN250x34.2
315	43,1-47,6	25	7,4	12	3	12	36	432	PE100RC SDR11 DN315x43.1
355	48,5-53,5	25	7,4	12	3	12	36	432	PE100RC SDR11 DN355x48.5
400	54,7-60,3	25	7,4	12	3	10	30	360	PE100RC SDR11 DN400x54.7

12 POLYETHYLENE PIPES ROBUST RC PE100RC BDS EN12201-2

DN [mm]	Wall Thickness [mm]	PN [bar]	SDR	Bars/rolls	*PACKAGING				Designation in project
					Nº of pipes / pallet	Pallets / truck	Nº of pipes / truck	Meters / truck	
32	2,0-2,3	10	17	100					PE100RC+PP SDR17 DN32x2.0
40	2,4-2,8	10	17	100					PE100RC+PP SDR17 DN40x2.4
50	3,0-3,4	10	17	100					PE100RC+PP SDR17 DN50x3.0
50	3,0-3,4	10	17	12					
63	3,8-4,3	10	17	100					PE100RC+PP SDR17 DN63x3.8
63	3,8-4,3	10	17	12	116	10	1 160	13 920	
75	4,5-5,1	10	17	100					PE100RC+PP SDR17 DN75x4.5
75	4,5-5,1	10	17	12	102	8	816	9 792	PE100RC+PP SDR17 DN75x4.5
90	5,4-6,1	10	17	100					PE100RC+PP SDR17 DN90x5.4
90	5,4-6,1	10	17	12	58	10	580	6 960	PE100RC+PP SDR17 DN90x5.4
110	6,6-7,4	10	17	12	48	8	384	4 608	PE100RC+PP SDR17 DN110x6.6
125	7,4-8,3	10	17	12	43	8	344	4 128	PE100RC+PP SDR17 DN125x7.4
140	8,3-9,3	10	17	12	38	6	228	2 736	PE100RC+PP SDR17 DN140x8.3
160	9,5-10,6	10	17	12	33	6	198	2 376	PE100RC+PP SDR17 DN160x9.5
180	10,7-11,9	10	17	12	17	8	136	1 632	PE100RC+PP SDR17 DN180x10.7
200	11,9-13,2	10	17	12	14	8	112	1 344	PE100RC+PP SDR17 DN200x11.9
225	13,4-14,9	10	17	12	14	6	84	1 008	PE100RC+PP SDR17 DN225x13.4
250	14,8-16,4	10	17	12	11	6	66	792	PE100RC+PP SDR17 DN250x14.8
280	16,6-18,4	10	17	12	7	8	56	672	PE100RC+PP SDR17 DN280x16.6
315	18,7-20,7	10	17	12	3	12	36	432	PE100RC+PP SDR17 DN315x18.7
355	21,1-23,4	10	17	12	3	12	36	432	PE100RC+PP SDR17 DN355x21.1
400	23,7-26,2	10	17	12	3	10	30	360	PE100RC+PP SDR17 DN400x23.7

* Robust RC pipes with integrated detector wire are produced in a diameter range up to DN200.
For diameter range DN≥225 mm pipes have no integrated detector wire.

DN [mm]	Wall Thickness [mm]	PN [bar]	SDR	Bars/rolls	*PACKAGING				Designation in project
					№ of pipes / pallet	Pallets / truck	№ of pipes / truck	Meters / truck	
32	2,0-2,3	16	11	100					PE100RC+PP SDR11 DN32x3.0
40	2,4-2,8	16	11	100					PE100RC+PP SDR11 DN40x3.7
50	3,0-3,4	16	11	100					PE100RC+PP SDR11 DN50x4.6
50	3,0-3,4	16	11	12					
63	3,8-4,3	16	11	100					PE100RC+PP SDR11 DN63x5.8
63	3,8-4,3	16	11	12	116	10	1 160	13 920	
75	4,5-5,1	16	11	100					PE100RC+PP SDR11 DN75x6.8
75	4,5-5,1	16	11	12	102	8	816	9 792	PE100RC+PP SDR11 DN75x6.8
90	5,4-6,1	16	11	100					PE100RC+PP SDR11 DN90x8.2
90	5,4-6,1	16	11	12	58	10	580	6 960	PE100RC+PP SDR11 DN90x8.2
110	6,6-7,4	16	11	12	48	8	384	4 608	PE100RC+PP SDR11 DN110x10
125	7,4-8,3	16	11	12	43	8	344	4 128	PE100RC+PP SDR11 DN125x11.4
140	8,3-9,3	16	11	12	38	6	228	2 736	PE100RC+PP SDR11 DN140x12.7
160	9,5-10,6	16	11	12	33	6	198	2 376	PE100RC+PP SDR11 DN160x14.6
180	10,7-11,9	16	11	12	17	8	136	1 632	PE100RC+PP SDR11 DN180x16.4
200	11,9-13,2	16	11	12	14	8	112	1 344	PE100RC+PP SDR11 DN200x18.2
225	13,4-14,9	16	11	12	14	6	84	1 008	PE100RC+PP SDR11 DN225x20.5
250	14,8-16,4	16	11	12	11	6	66	792	PE100RC+PP SDR11 DN250x22.7
280	16,6-18,4	16	11	12	7	8	56	672	PE100RC+PP SDR11 DN280x25.4
315	18,7-20,7	16	11	12	3	12	36	432	PE100RC+PP SDR11 DN315x28.6
355	21,1-23,4	16	11	12	3	12	36	432	PE100RC+PP SDR11 DN355x32.2
400	23,7-26,2	16	11	12	3	10	30	360	PE100RC+PP SDR11 DN400x36.3

* Robust RC pipes with integrated detector wire are produced in a diameter range up to DN200.
For diameter range DN≥225 mm pipes have no integrated detector wire.

13 POLYETHYLENE PRESSURE PIPES DIAGRAM OF FRICTION LOSSES

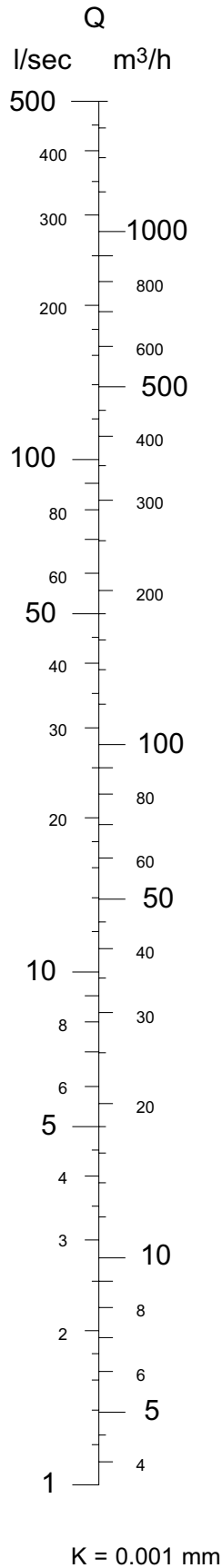

$$h = \frac{\lambda \cdot v^2}{2 \cdot g \cdot d} \quad (\text{water at } 15^\circ\text{C})$$

h = hydraulic gradient (pressure loss from friction) (m/100 m)

v = average flow velocity (m/sec)

Q = flow (l/sec или m³/h)

I.D. = inside diameter (mm)

λ = coefficient of losses

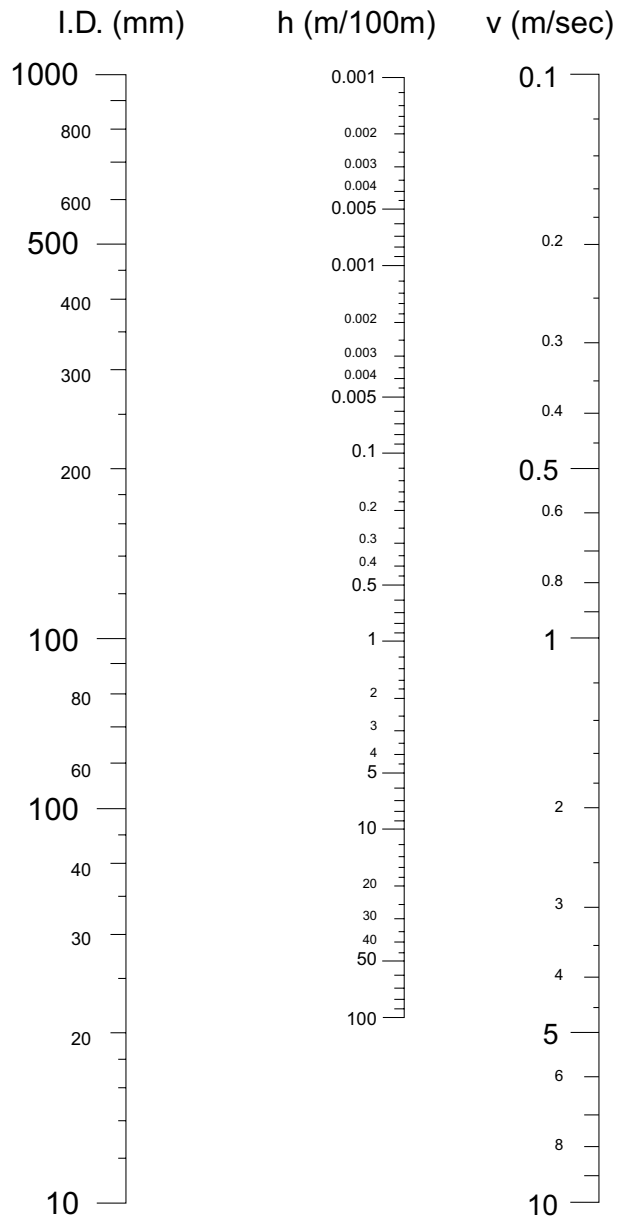

14 DIAGRAM OF THE COEFFICIENT FOR CORRECTION OF FRICTION LOSSES IN POLYETHYLENE PRESSURE PIPES (AS FUNCTION OF THE TEMPERATURE)

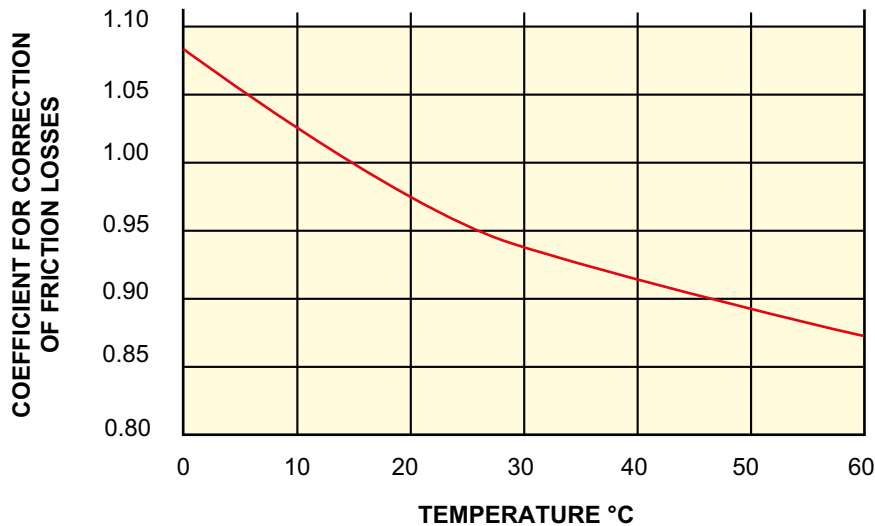

15 HIGH DENSITY POLYETHYLENE PIPES: CORRELATION BETWEEN THE PRESSURE NORMS AND THE ALLOWED TEMPERATURES UNDER DIFFERENT CONDITIONS OF CONSTANT USE

To use a certain system at temperatures, different from 20°C or for a period of 50 years, it is necessary its values to be reduced or raised in accordance with the maximum work pressure or the term of operation or a combination of both.

TEMPERATURE (°C)	YEARS OF EXPLOITATION	PN 2.5 Series 1	PN 3.2 Series 2	PN 4 Series 3	PN 6 Series 4	PN 10 Series 5	PN 12.5	PN 16 Series 6
10	1	3.4	4.3	5.4	8.0	13.4	16.7	21.4
	5	3.2	4.1	5.1	7.7	12.8	16.0	20.5
	10	3.2	4.0	5.0	7.6	12.6	15.8	20.2
	25	3.1	3.9	4.9	7.3	12.2	15.2	19.5
	50	3.0	3.8	4.8	7.2	12.0	15.0	19.2
20	1	2.9	3.6	4.6	6.8	11.4	14.2	18.2
	5	2.7	3.5	4.3	6.5	10.8	13.5	17.3
	10	2.7	3.4	4.2	6.4	10.6	13.3	17.0
	25	2.6	3.3	4.2	6.2	10.4	13.0	16.6
	50	2.5	3.2	4.0	6.0	10.0	12.5	16.0
30	1	2.5	3.1	3.9	5.9	9.8	12.2	15.7
	5	2.4	3.0	3.8	5.6	9.4	11.7	15.0
	10	2.3	2.9	3.7	5.5	9.2	11.5	14.7
	25	2.0	2.5	3.1	4.7	7.8	9.8	12.5
	50	1.7	2.2	2.7	4.1	6.8	8.5	10.9
40	1	2.1	2.7	3.4	5.0	8.0	10.0	12.8
	5	1.8	2.3	2.9	4.3	7.2	9.0	11.5
	10	1.6	2.0	2.5	3.7	6.2	7.8	9.9
	25	1.3	1.7	2.1	3.1	5.2	6.5	8.3
	50	1.2	1.5	1.8	2.8	4.6	5.8	7.4
50	2	1.7	2.2	2.7	4.1	6.8	8.5	10.9
	5	1.2	1.5	1.9	2.9	4.8	6.0	7.7
	10	1.1	1.3	1.7	2.5	4.2	5.3	6.7
	30	1.0	1.3	1.6	2.4	4.0	5.0	6.4
60	1	1.2	1.5	1.9	2.9	4.8	6.0	7.7
	5	0.8	1.1	1.4	2.0	3.4	4.2	5.4
70	1	0.8	1.0	1.3	1.9	3.2	4.0	5.1

16 HIGH DENSITY POLYETHYLENE PIPES FOR PRESSURE OF ATM, DIAGRAM OF SUPPORTS ARRANGEMENT

(PIPE WITH WATER, D 1000 KG/M3, RADIUS OF BENDING MAX 10 MM FOR 10 YEARS)

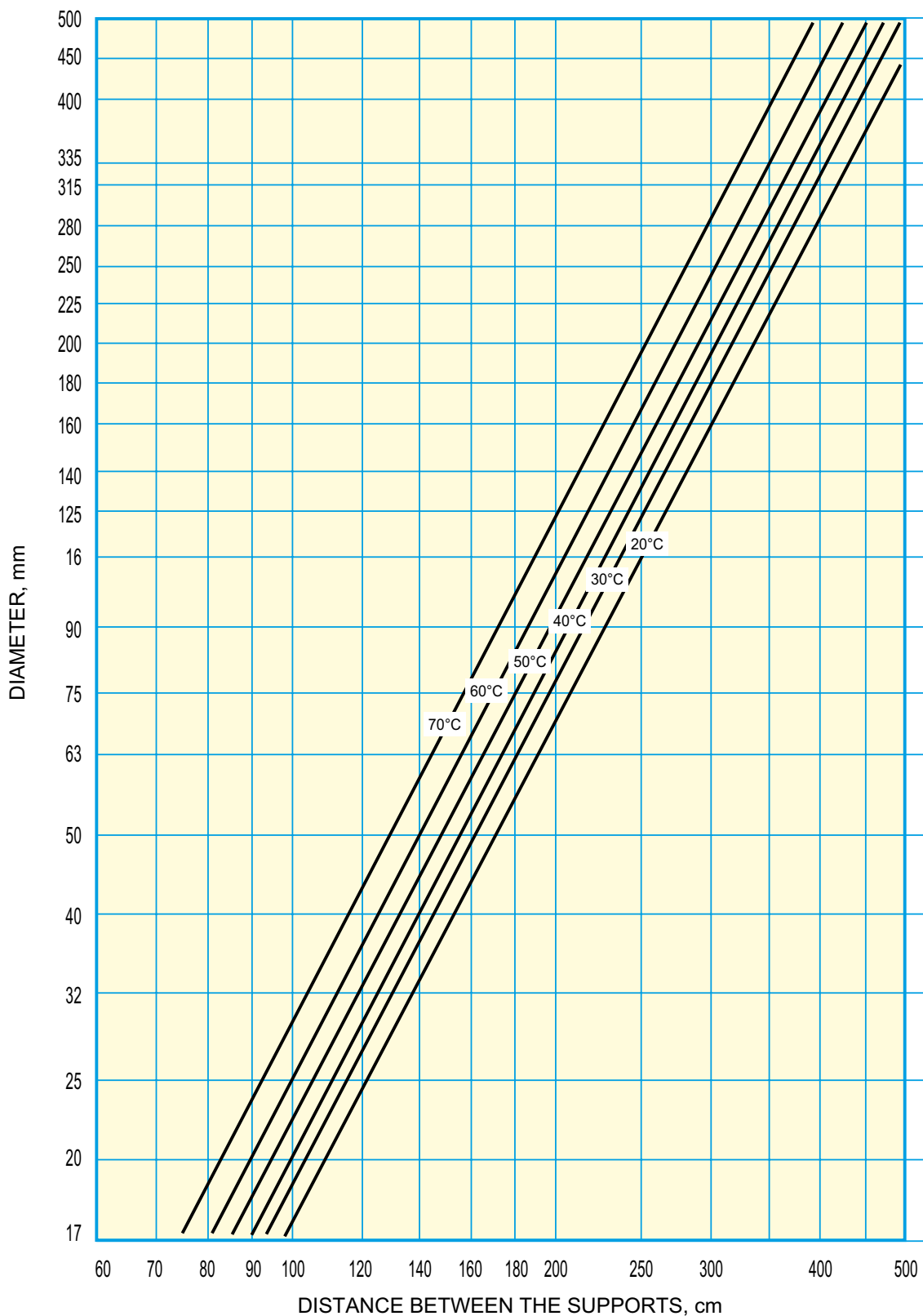

The distances between the supports according to the diagram concern only the horizontal pipes. For the vertical pipes, the indicated distances must be multiplied by coefficient of 1.3.

17 HIGH DENSITY POLYETHYLENE PIPES, COEFFICIENT FOR CORRECTIONS OF THE SUPPORT ARRANGEMENT

The following tables indicate the coefficient for correction in the distances between the supports for high density polyethylene pipes (HDPE) or PVC-U, during the pipeline installation under conditions which are different from the ones, indicated in the previous diagram.

TABLE WITH CORRECTIONS FOR DIFFERENT NOMINAL PRESSURES

COEFFICIENT FOR CORRECTION	
NOMINAL PRESSURE (atm)	HDPE
PN 16	1.07
PN 12.5	1.03
PN 10	1.00
PN 6	0.91
PN 4	0.84
PN 3.2	0.80
PN 2.5	0.75

TABLE WITH CORRECTIONS FOR DIFFERENT RADII OF BENDING

COEFFICIENT FOR CORRECTION	
RADIUS OF BENDING (mm)	HDPE
20	1.19
15	1.11
10	1.00
5	0.84
2.5	0.70
1	0.56

TABLE WITH CORRECTIONS FOR FLUIDS WITH DENSITY WHICH IS DIFFERENT FROM THE WATER ONE

COEFFICIENT FOR CORRECTION	
FLUID DENSITY (Kg/m ³)	HDPE
1000	1.00
1250	0.96
1500	0.93
1750	0.90

18 CALCULATION OF PLAST PIPES DEFLECTIONS

For the calculation of plastic pipe deflection under the soil pressure with which it is covered, the following procedure is observed.

CALCULATION OF THE SOIL STATIC PRESSURE, PS (FIGURE 2)

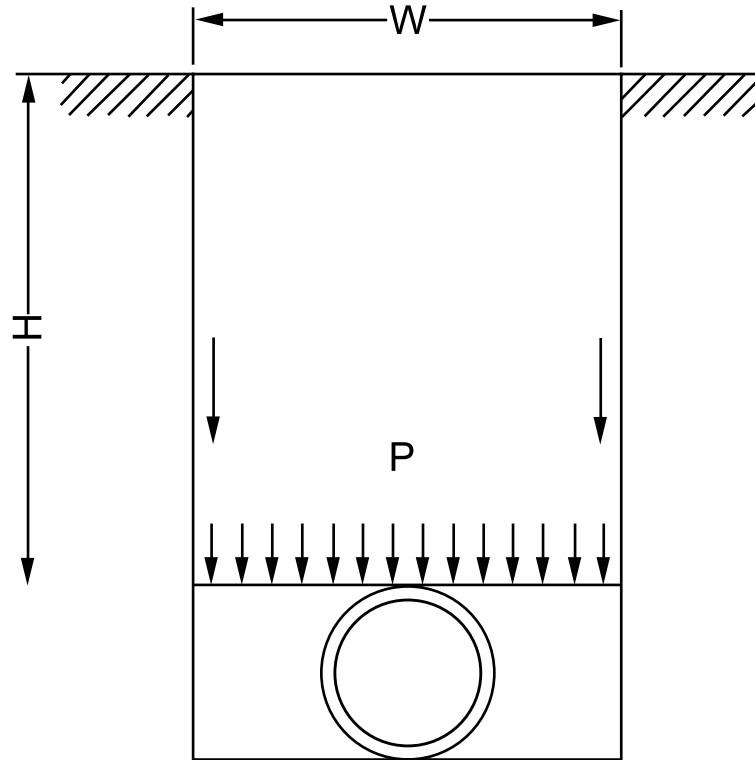

Figure 2

$$P_s = c \cdot \gamma \cdot H$$

and

$$c = \frac{1 - e^{-2 \cdot k \cdot \epsilon \cdot \phi \cdot \delta \cdot H/W}}{2 \cdot k \cdot \epsilon \cdot \phi \cdot \delta \cdot H/W}$$

Where

P_s = soil pressure over the upper part of the pipe (kg/m^2)

γ = soil specific weight (kg/m^3)

H = depth of the cover (m)

W = trench width (m)

c = coefficient of pressure according to the soil type

k = coefficient related to the vertical and horizontal pressure

δ = angle of friction of the filling material (bedding angle)

The values of k and δ are taken from Table II.

TABLE II

Properties of the material for filling the trenches	K	δ(Table IV)
- The material for filling is compacted to a certain degree	0.5	δ = ρ
- There is a trench		
- The material for filling is not compacted enough	0.5	δ = 2/3ρ
- Vertical walls of the trench are set up for support of the soil		
- There are underground waters	0.7	δ = ρ
- The material is compacted enough dense soil Dp > 95% crumbly soil Dp > 97%		

CALCULATION OF TRAFFIC LOAD, PW (FIGURE 3)

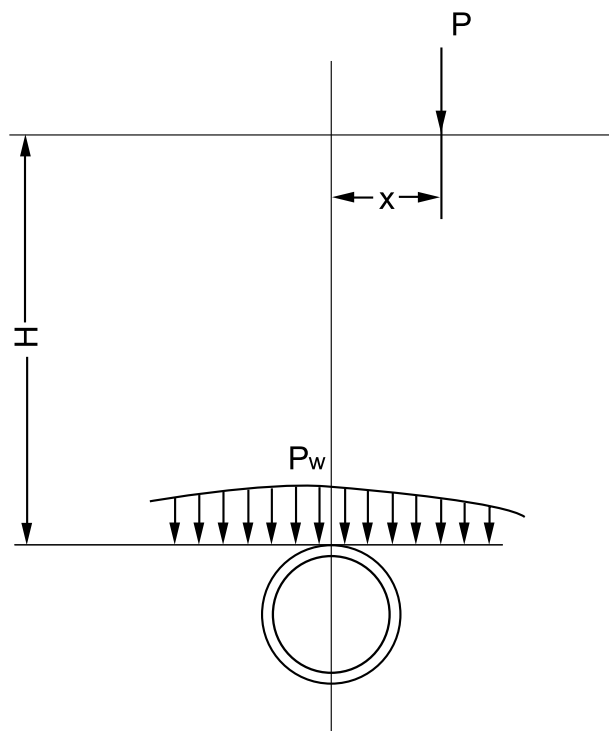

Figure 3

It is recommended in all cases the cover layer to be deeper (H) than 0.8 m. The following formula is not valid for $H < 0.5$ m.

$$P_w = \frac{3 \cdot P}{2 \cdot \pi \cdot H^2 \left\{ 1 + \frac{x^2}{H^2} \right\}^{5/2}}$$

Where

P = car's weight (kg)

x, H = distances in (m), as shown on Figure 3 (m).

- Total load

The total load (q) is calculated with the formula:

$$q = P_s + P_w \text{ kg/m}^2 = q / 10000 \text{ kg/cm}^2$$

If the pipe is ideally buried on the trench bottom and if the soil filled in laterally, above and at the ends is well compacted, only part of the load influences the pipeline walls. That is why the formula changes as:

$$q_r = 0,5 \cdot q = q_r / 10000 \text{ kg/cm}^2$$

- Calculation of the pipe's section stiffness, R_t

$$R_t = \frac{2 \cdot E \cdot s^3}{3 (D_n - s)^3}$$

Where

D_n = pipe's nominal diameter (cm)

s = pipe's thickness (cm)

E = modulus of elasticity (kg/cm²)

**TABLE III
MODULUS OF ELASTICITY**

E_t	uPVC	PE 80 (2 nd)	PE 100 (3 rd)
Long-term elasticity	30000	6500	14000
Short-term modulus	20000	1650	3500

- Calculation of soil stiffness, R_e

$$R_e = 0,6 \cdot e \cdot E_e$$

Where

e = coefficient for correction

E_e = modulus of elasticity, second modulus of the surrounding burying material (Table IV)

**TABLE IV
MODULUS OF ELASTICITY OF THE SOIL AROUND THE PIPE**

Soil group (according to ATV)	Specific weight γ (gr/cm ³)	Angle of friction ρ (°)	E_e (kg/cm ²), Depending on				
			85%	90%	95%	97%	100%
Crumbly soil, big granules (gravel)	2	35	25	60	160	230	400
Lightly compacted soil, fine granules (sand)	2	30	12	30	45	80	200
Dense mixed soil, slime (sand and gravel)	2,1	25	10	20	30	60	160
Dense soils (clay)	2	20	6	15	20	40	100

- Calculation of the system stiffness (pipe's section-surrounding soil), R_s

$$R_s = \frac{R_t}{R_e}$$

- Calculation of pipe's deflection, ΔD_n and Def

$$\Delta D_n = \frac{q_r \cdot D_n}{2R_t} \cdot \xi \quad \text{and} \quad \xi = -0.166 + 0.128 \cdot L$$

$$L = \frac{0,083}{R_s + 0,066} \quad \text{and} \quad \text{Def} = \frac{\Delta D_n}{D_n} \cdot 100 \%$$

Where

ΔD_n = diameter change (cm)

Def = deflection (%)

An example of deflection calculation

Sewer pipes PE 100 0400 (thickness 14 mm) are buried in the ground at the depth of 2.6 m, in a trench which is 1 m. wide. The trench is filled with lightly compacted gravel ($D_p = 90\%$ according to Proctor). The soil specific weight is $= 2000 \text{ kg/m}^3$ and the angle of friction is $p = 35\%$. The load of the passing vehicles is 30.000 kg.

- Calculation of the static pressure of the soil, P_s

$$c = \frac{1 - e^{-2 \cdot 0,5 \cdot \varepsilon \cdot \varphi \cdot 35 \cdot 2,6/1}}{2 \cdot 0,5 \cdot \varepsilon \cdot \varphi \cdot 35 \cdot 2,6/1} = 0,46$$

$$P_s = 0,46 \cdot 2000 \cdot 2,6 = 2393,75 \text{ kg/m}^2$$

- Calculation of the traffic load

$$P_w = \frac{3 \cdot 30,000}{3 \cdot \pi \cdot 2,6^2} = 2,120 \text{ kg/m}^2$$

$$q = 2,393 + 2,120 = 4,513 \text{ kg/m}^2 = 0,4513 \text{ kg/cm}^2$$

$$q_r = q \cdot 0,5 = 0,2256 \text{ kg/cm}^2$$

- Calculation of the pipe's section stiffness, R_t

$$R_t = \frac{2 \cdot 3,500 \cdot 1,4^3}{3 \cdot (40 - 1,4)^3} = 0,111$$

- Calculation of the soil stiffness, R_e

$$R_e = 0,6 \cdot 1 \cdot 60 = 36 \text{ kg/m}^2$$

- Calculation of the system stiffness (soil - pipe), R_s

$$R_s = 0,111/36 = 0,0031$$

- Calculation of pipe's deflection, ΔD_n and Def

$$L = \frac{0,083}{0,00031 + 0,066} = 1,201$$

$$\xi = -0.166 + 0.128 \cdot L = -0.012$$

$$\Delta D_n = \frac{0,2256 \cdot 40}{2 \cdot 0,111} \cdot (-0,012) = 0,488 \text{ cm}$$

$$\text{Def} = \frac{0,488}{40} \cdot 100 = 1,22 \%$$

19 STRENGTH AT LONGITUDINAL BENDING OF PIPES UNDER THE INFLUENCE OF EXTERNAL HYDROSTATIC PRESSURE

The external pressure for example of the soils and of the underground waters creates contraction forces around the pipe's wall. When the contraction forces around the pipe's walls exceed a certain limit, it is possible the elliptical deformed pipe to crumple due to the bending of the wall.

The theoretical resistance to longitudinal bending (P_b) is calculated according to the following equation:

$$P_b = \frac{24 \cdot E \cdot I}{(1 - \nu^2) \cdot D_m^3}$$

And because $I = \frac{s^3}{12}$

$$P_b = \frac{2 \cdot E}{(1 - \nu^2)} \left(\frac{s}{D_m} \right)^3$$

Where

P_b = load with longitudinal bending (kgf/cm²)

E = modulus of elasticity of pipe's material (kgf/cm²)

s = wall thickness (cm)

D_m = average diameter of the pipe (cm)

ν = coefficient of Poisson

The formula validity depends on the pipe's elasticity and circumference. If the pipe has deflections and elliptic shape, then the load with longitudinal bending P_b must be corrected with a coefficient whose value, according to the pipe's deflection, is taken from Diagram 1.

DIAGRAM 1

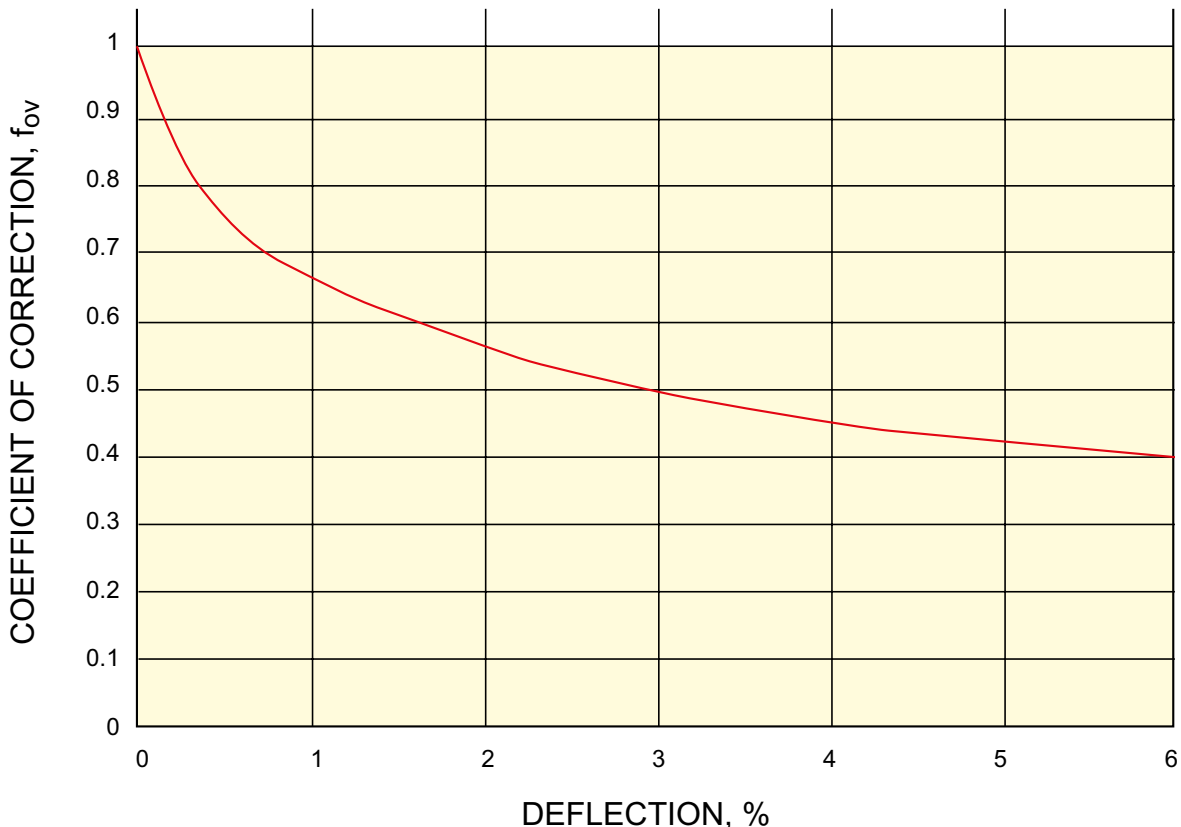

When the pipe is buried in the ground, it touches the surrounding soil. If the soil is well compacted and has a high modulus of elasticity, then the pipe's support is considerable and must be taken into account by using the coefficient f_s , which is taken from Diagram 2 in accordance with the work pressure of the pipe.

DIAGRAM 2

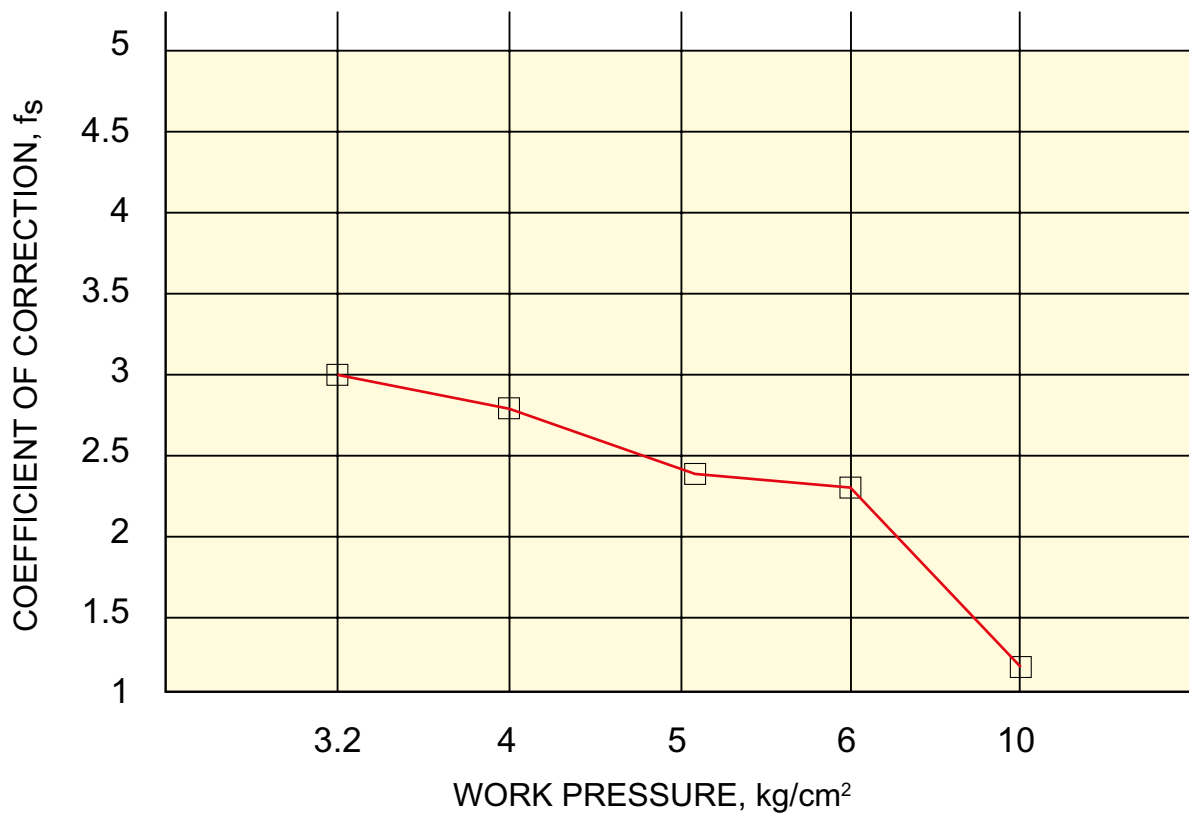

That is why when we lay a pipe in the ground, we have the following:

$$P'_b = P_b \cdot f_{ov} \cdot f_s$$

The pipes which are submerged at the depth H_w , are under the influence of external (hydrostatic) pressure, calculated according to the following formula:

$$P_w = \frac{\gamma_w \cdot H_w}{10,000}$$

Where

P_w = external (hydrostatic) pressure (kgf/m²)

γ_w = specific weight of water (kgf/m³)

H_w = water depth above the pipe (m)

With the help of the safety coefficient ($S = 2$) we can calculate the maximum depth (H_{wmax}), at which the pipe can work reliably.

$$H_{wmax} = \frac{10,000 \cdot P'_b}{2 \cdot \gamma}$$

20 POLYETHYLENE PIPES TRANSPORTATION AND STORAGE

To preserve their technical properties the polyethylene pipes must be used, transported and stored in accordance with the following instructions.

A. TRANSPORTATION

- The pipes must be transported in suitable vehicles with smooth inner surface which doesn't allow the damage of the pipes.
- The pipes must not be pulled over the surfaces of the vehicle, must be properly loaded, put one over other on smooth surfaces and unloaded. If the pipe's wall has a scratch, deep 10% of the wall's thickness, it is recommended this part to be replaced.

B. STORAGE

- During the storage the pipes must not be bended or damaged. Such problems are possible if the pipes are not arranged properly to a certain height. The pipes must not be arranged standing and one over other higher than 1.5 m, and the areas for storage must be smooth without stones and other sharp objects along the pipe. If the pipes are manufactured with fittings, the fittings must be sticking out.
- The pipes with different diameters must be stored separately. If this is impossible, the pipes with bigger diameter must be stored at the bottom of the package.
- When the pipes are stored for a long period, spirally rolled, they must be stored horizontally.

21 POLYETHYLENE PIPES INSTALLATION

A. UNDERGROUND NETWORKS

Compared to the conventional, the polyethylene pipes can be buried in trenches with smaller dimensions. The long, butt welded pipes, connected above ground, can be buried in narrow trenches, after being left to cool. In principle the dimensions of the trenches are defined according to the diameter of the pipes, the method of connection and the soil type.

The trench depth must exceed:

- 50 cm for roads without traffic;
- 60 cm for roads with poor traffic;;
- 80 cm for roads with normal or busy traffic..

The trench width can be as small as possible but not smaller than the pipe's diameter plus 20 cm in order to allow proper compacting of the lateral filling material and proper distribution of the soil pressure over the pipe. The bottom of the trench must be smooth without stones and other sharp or hard objects. It is necessary to be covered with a layer of sand 10-15 cm thick (bedding layer) which provides an even support of the buried polyethylene pipe. If it has no stones the dug soil can be used as a lateral material for filling.

B. ABOVE-GROUND NETWORKS

Using of above-ground networks allows utilizing of the inherent properties and characteristics of the material as resistance to deterioration from sunlight, good resistance to impacts even at low temperatures, big flexibility and others.

The basic precautions in this case are:

- Protection from overheating. The pipelines must not be placed near steam generators, steam pipelines and others due to the danger of overheating above the allowed value.
- Providing of supports for the pipelines at certain intervals, especially for the parts with heavy fittings (for example valves).

C. SUBMERGED NETWORKS

The decision for burying underground and the responsibility for this procedure execution depend totally on the subcontractor and most of all on the means which he has. The work site must be smooth and close to the bank. If the pipes are delivered rolled on spiral, enough space must be provided (at least 100 m) for their unwinding.

The polyethylene density is lower than 1 gr/cm^3 . Due to this the pipes must be buried with additional weights (ballast), which hold the pipes steady on the sea bottom. The weights are made of concrete (armored or not) and can be in different shapes. To avoid damaging of the external surfaces of the pipes from the concrete weights, usually the latter are coated with soft material (for example polyethylene foil).

D. RADIUS OF BENDING

At normal temperatures the polyethylene pipes can be bended to a radius R_s , which is equal to 12-20 times their external diameter (DIN 16933). The inherent flexibility of the polyethylene pipes allows being avoided significant number of fittings during the design and building of pipeline system. If the pipes are delivered rolled on spiral or on spools, they must be bended at the direction of winding.

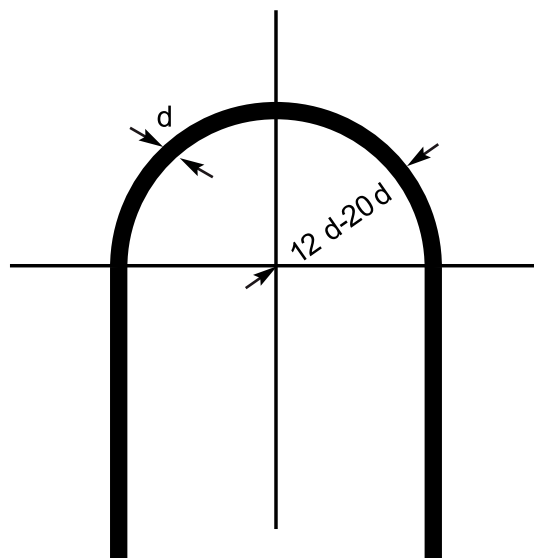

22 POLYETHYLENE PIPES CONNECTION

A. WELDING

Polyethylene can be welded. Welding is a process of thermal connecting by heating to 220°C of the surfaces of the circle openings of the connected polyethylene pipes until reaching a state of melting of every contact surface. After that the two surfaces are joined under controlled pressure for a certain period for cooling and by joining the molecules of the two pipes a homogeneous welding is achieved.

- The spots for joining are resistant to axial pressure and under pressure their strength can be compared with the pipe's one.
- Polyethylene pipes flexibility and the flexibility of the joining allow the designer to connect the pipes on the ground surface and after that to bury them in the trench, regardless of the used burying technique.
- Continuity and smoothness of the internal surface of the pipes are preserved and the coefficient of roughness (k) is not increased. Even if it is necessary the stripe which is formed as a result of the welding can be easily removed.

1. BUTT WELDING



Thermal alloy butt welding is fully applicable when welding two PE100RC pipes, one PE100 pipe and one PE100RC pipe and two PE100RC pipes with an additional protective PP layer.

For the butt welding of polyethylene pipes a special welding machine is necessary with heating plate (“mirror”) for heating the pipe’s end to melting point which later on are connected under pressure. The principle sequence of the welding procedure is illustrated on Figure 4.

- The pipes’ ends, tightened up in the welding machine, are made smooth with the help of a smoothing device. In this device the pipe’s ends are checked for axial alignment.
- The pipes’ ends are pressed towards the heating element with the necessary pressure P for smoothing until the moment when the joining surfaces are melted all around their circumference and on the internal and the external parts of the pipes a stripe is formed which 2 mm high.
- The pressure for aligning is reduces almost to zero and the time for heating begins to go by. The heating without pressure continues until the melting of the necessary polyethylene mass around the heated area.
- The pipes’ ends are released from the heating element which is removed without touching the fusion surfaces and then immediate connecting of the pipes is made under welding pressure P .
- The welding pressure P is maintained during the whole period of cooling.

The time for cooling, the heating pressure and the welding and the height of the formed welding stripe depend on the parameters of the welded pipes (diameter, wall thickness).

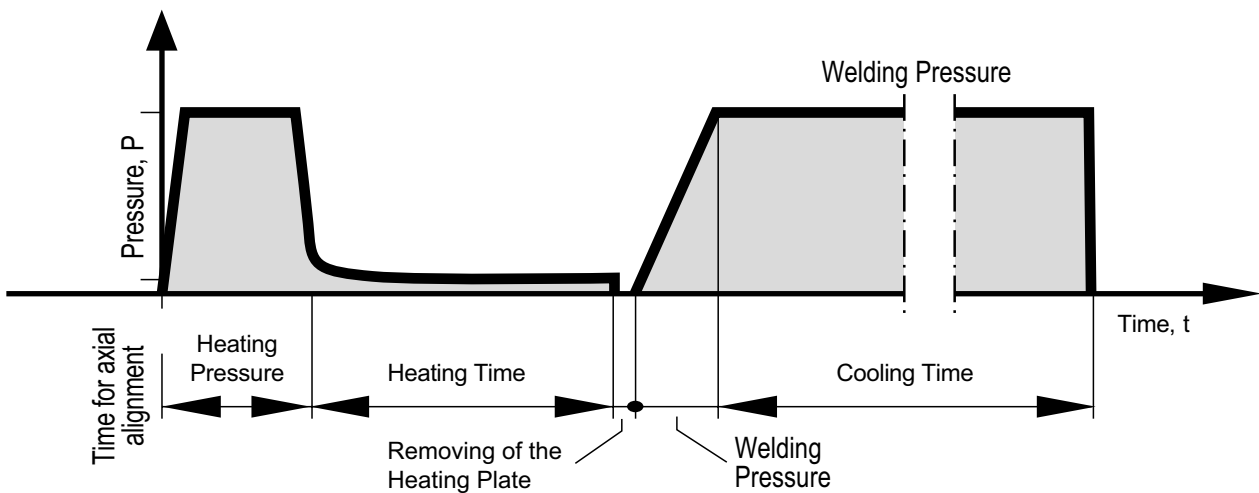

2. FUSION WELDING



During the fusion welding it is required a special aggregate for welding control, which sends heat energy (direct current) towards the special polyethylene fitting for melting.

The fitting is a connecting device with two nests with a heating element (wire), formed along the surface for welding at the joining points. When the two leveled ends of the pipe are inserted into the device and electricity

is applied, the heat, generated at the element welds together the joined surfaces. The time for welding and the application of electricity, which depend on the diameter and the fitting type, are regulated manually or automatically by a control panel.

2.1 MAKING OF A DEFLECTION THROUGH ELECTRO WELDED MULTISEAL TAPPING TEE

- Multiseal Tapping Tee - Saddle connection



- Multiseal Tapping Flexible Tee



B. MECHANICAL CONNECTION

The mechanical connection of polyethylene pipes is achieved by appropriate mechanical fittings. They are made of different materials (plastic and metal) and are two types:

- Fittings for multiple uses which can be taken off the pipe and used again.
 - Permanently mounted fittings which cannot be taken off the pipe.
- **through all-purpose socket for connecting pipes of different material**



- **through PUSHFIT fittings**



- etc.

23 BUTT WELDING: WELDING PRESSURE (Kp)

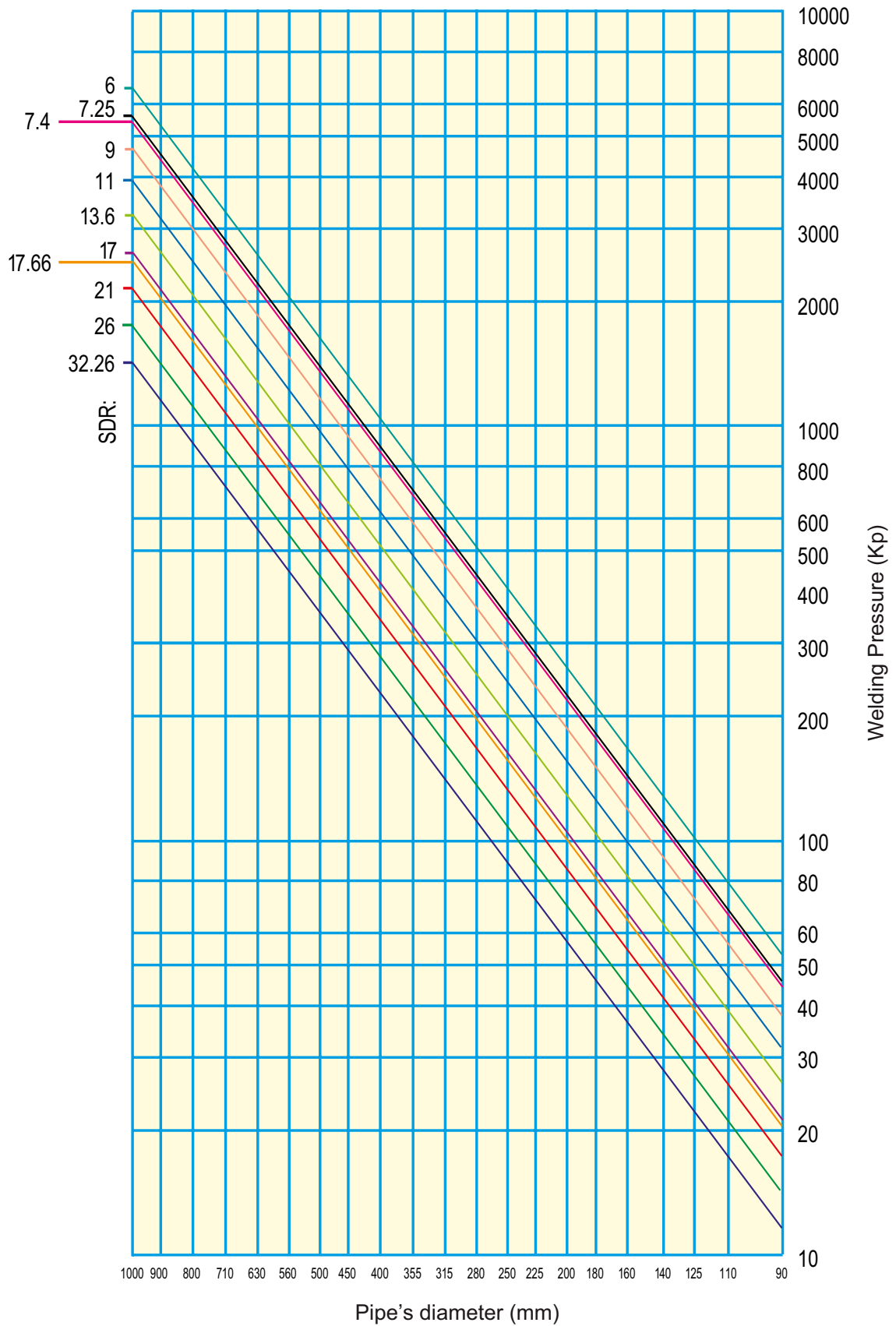

Manometer readings (bar) = welding force / f*

*The coefficient f is usually indicated by the manufacturer of the machine, with usual value 1bar = fKp.

24 BUTT WELDING: TIME OF HEATING AND COOLING

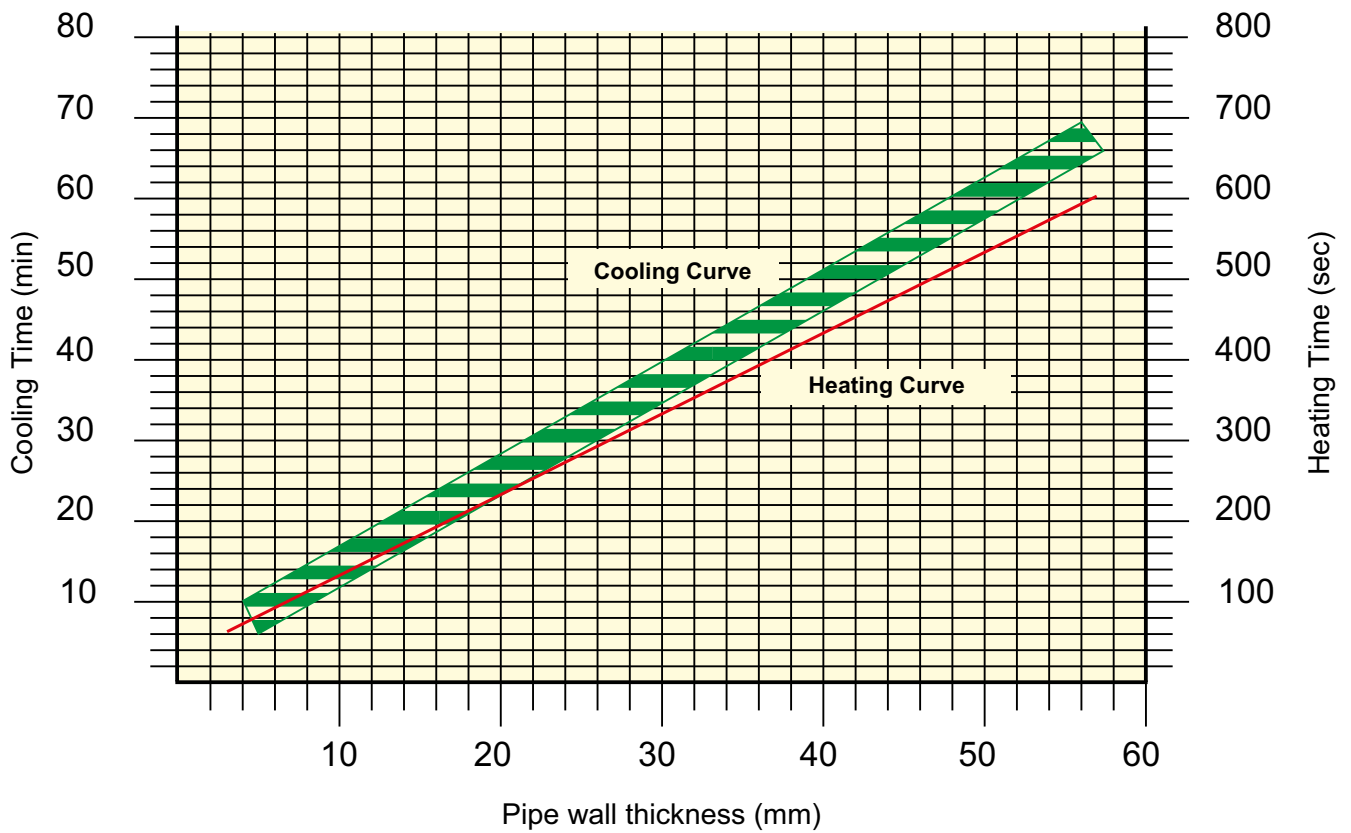

Again the total time for butt welding is determined to a great extent by the time for preparation i.e. the time necessary for:

- Joining the pipes
- Leveling
- Providing of axial alignment
- Cleaning

It is obvious that properly prepared work site and the welders' experience play a significant role for the total time, necessary for the butt welding procedure.

Note: The time for cooling varies according to the temperature of the environment.



Measure and mark the pipe.



Place the cutting tool between the outer and inner layer.



With light pumping movements, move the tool to the mark.



Rotate the tool by holding firmly with your thumb and remove the outer layer of the pipe.



Pull the peeled layer.



The inner layer is ready for smoothing and soldering(welding).

It should be borne in mind that in pipes with an additional protective layer of PP, immediately before welding (front or electrofusion), it must be removed in the area around the weld. This is an important requirement, i.e. the polyethylene, of which the

base pipe is made, and the polypropylene, of which the protective layer is made, have different indexes of melting and may even initially have alloying and diffusion between the two materials, in the long run there will be dissociation between them,

loss of weld strength and pipeline failure.

The figure below shows the connection of the detector wire between two welded tubes with an additional thermoplastic cuff.

After the welding we connect the detector wire (if any) via a terminal.

Restore the protective layer with shrink film, suitable for the protective layer(PE or PP). First coil the shrink film and then warm up with hot air the separate layers and after that their connection with the protective layer. The restored protective layer thickness should be at least equal to the existing one.



25 BASIC TESTS OF PRESSURE POLYETHYLENE PIPES ACCORDING TO BDS EN 12201-2

- **Extension at tear**

The tear should occur at an extension greater than 350% of the original length of the test piece.



- **Hydrostatic strength**



Test	Duration	Requirement	Material	Number of test bodies	Medium	Tangential stresses in the wall
Hydrostatic strength at 20°C	100 hours	No destruction of any sample body during the whole test	PE80	3	Water in water	10 MPa
			PE100	3	Water in water	12.4 MPa
Hydrostatic strength at 80°C	165 hours	No destruction of any sample body during the whole test	PE80	3	Water in water	4.5 MPa
			PE100	3	Water in water	5.4 MPa
Hydrostatic strength at 80°C	1000 hours	No destruction of any sample body during the whole test	PE80	3	Water in water	4.0 MPa
			PE100	3	Water in water	5.0 MPa

26 RESISTANCE CERTIFICATION OF POLYETHYLENE PRESSURE PIPES

In addition to the basic tests of the BDS EN 12201-2 standard, if a pressure polyethylene tube has to be certified as RC - resistant to crack, it needs to undergo further testing.

In Europe, two basic methodologies have been established according to which tests to prove the tube as an RC tube are carried out.

PAS 1075 - this is a methodology created and established in Germany.

PW 405 / 1- this is a methodology created and established in Austria.

There are virtually no differences between the two methodologies.

Here are some of the basic tests needed to certify a pressure polyethylene pipe as an RC pipe:

- **Test by stretching a piece of raw material with a peripheral cut (Full Notch Creep Test)**

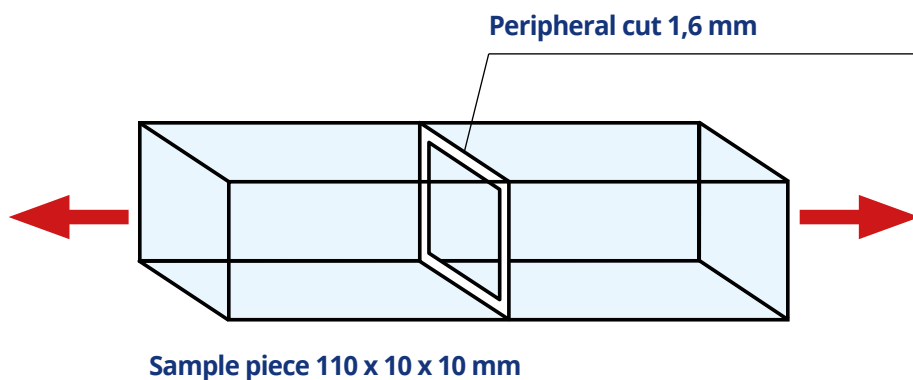

Figure 23

- Point Loading Test

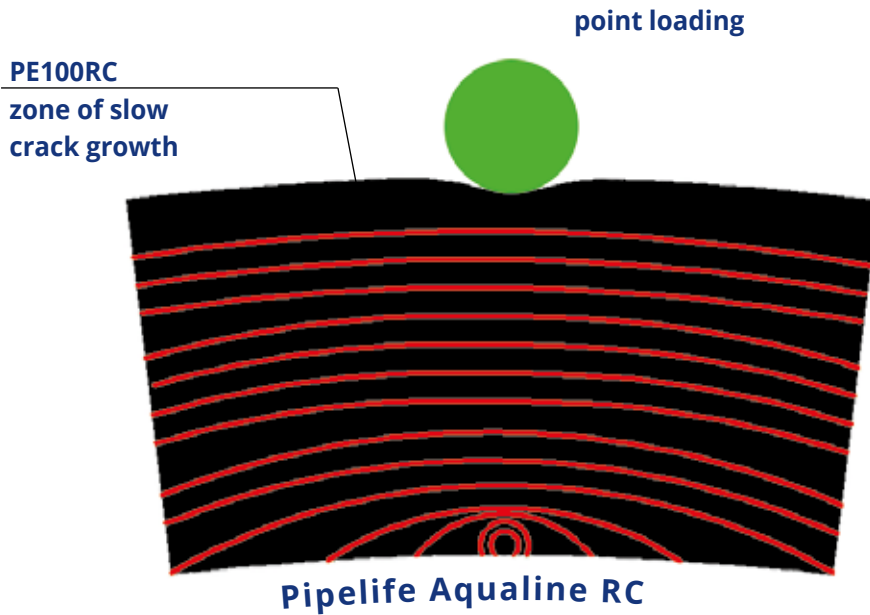

Figure 24

- Notch Pipe Test

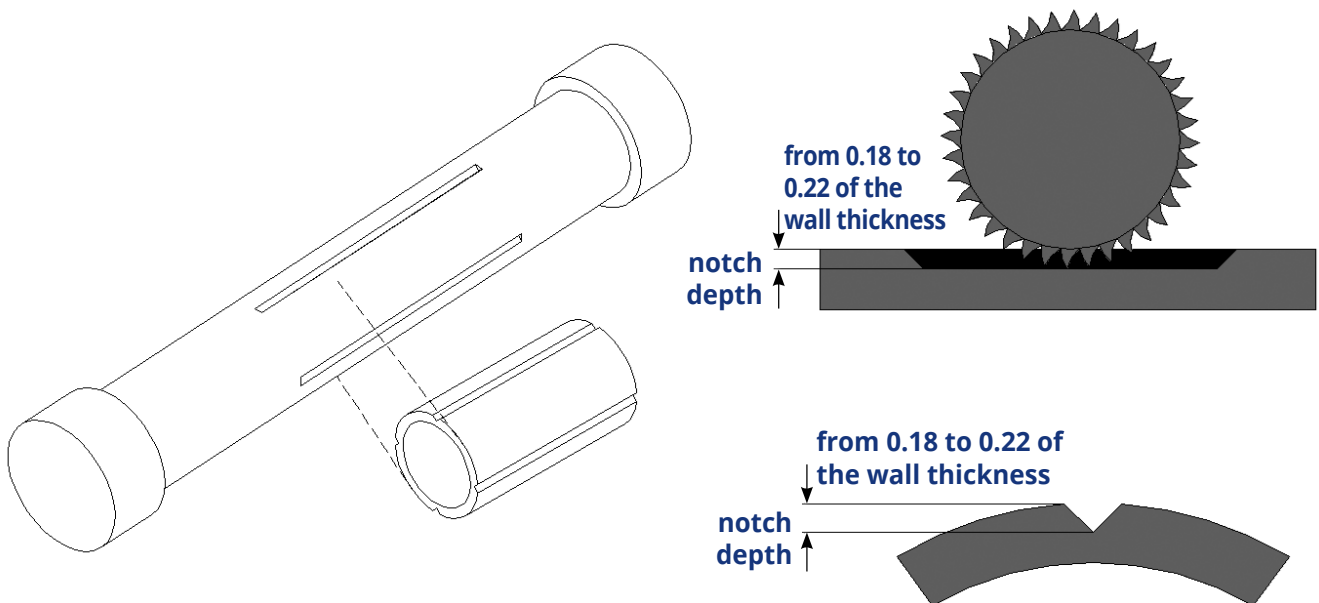

Figure 25

In the certification of pipes as crack-resistant, two main groups of tests are performed. Testing of the raw material (granule) and testing of produced pipes.

When testing the raw material, test pieces of the sample are preassembled in the form of a prism in the Full Notch Creep Test or a test piece of extruded pipe at the Point Loading Test and the Notch Pipe Test.

When testing the pipes, a Point Loading Test and a Notch Pipe Test of finished products are made. Full Notch Creep Test is not done on finished products (produced pipes).

COMPARISON OF THE TESTS AS PER THE PW405 / 1 AND PAS 1075 METHODS

Tests of the raw material (granule) for resistance to slow crack growth

Test	Test sample	Temperature	Tension	Medium	Duration	Scope in first test	Scope in own control	Scope in yearly check	Method PW405/1	Method PAS 1075
Full Notch Creep Test	Pressed plate	80°C	4,0 MPa	Water with 2% arcopal N100	> 8760 h	6 pc. per material	3 pc. per material	3 pc. per material	Yes	Yes
Point Loading Test	Pipe DN/OD 110 SDR11	80°C	4,0 MPa	Water with 2% arcopal N100	> 8760 h	3 pc. per material	-	1 pc. per material of 3 years	Yes	Yes
Notch Pipe Test	Pipe DN/OD 110 SDR11	80°C	4,0 MPa	Water with 2% arcopal N100	> 8760 h	3 pc. per material	2 pc. per material	1 pc. per material of 3 years	Yes	Yes

Tests of produced pipes for resistance to slow crack growth

Test	Test sample	Temperature	Tension	Medium	Duration	Scope in first test	Scope in own control	Scope in yearly check	Method PW405/1	Method PAS 1075
2 Notches	Pipe	80°C	4,0 MPa	Water with 2% arcopal N100	> 3300 h	3 pc. per production group	3 pc. per material	3 pc. per size	Yes	Yes
Pipe Test	Pipe	80°C	4,0 MPa	Water with 2% arcopal N100	> 8760 h	3 pc. per production group	-	1 pc.	Yes	Yes
Point Loading Test	Pipe DN/OD 110 SDR11	80°C	4,0 MPa	Water with 2% arcopal N100	> 8760 h	3 pc. per production group	2 pc. per material	3 pc. per size	Yes	Yes

Tests of protective coatings

Test	Test sample	Temperature	Tension	Medium	Duration	Scope in first test	Scope in own control	Scope in yearly check	Method PW405/1	Method PAS 1075
Penetration Test	Pipe (the remainder of the wall thickness must be > 50% of the thickness of the wall before the test)	20°C 40°C 60°C 80°C	7,48 MPa 5,81 MPa 4,66 MPa 3,82 MPa	Water with 2% arcopal N100	> 9000 h	3 pc. per production group	-	-	Yes	Yes

In conclusion, it can be said that the two opinions are identical.

The **AquaLine RC** and **Robust RC** pipes for underground pressure pipelines without a sanding pad and sanding in the area around the pipe have an official statement by the AUSTRIAN FEDERAL INSTITUTE OF TECHNOLOGY, PLASTICS TECHNOLOGY AND ENVIRONMENTAL ENGINEERING, according to which the tests as per ÖVGW / GRIS QS-W tests 405/1 cover all PAS1075 (Full Notch Creep Test, Point Load Test, Penetration Test) tests, as well as the additional for ÖVGW specific tests. You can see the statement itself below.



Staatliche Versuchsanstalt

Kunststoff- und Umwelttechnik

FEDERAL INSTITUTE OF TECHNOLOGY
PLASTICS TECHNOLOGY AND
ENVIRONMENTAL ENGINEERING

Pipelife Austria GmbH & Co KG
z.H. Hr. DI (FH) Werner Sens MSc
IZ NÖ-Süd Straße 1
A-2355 Wr. Neudorf

your sign	your message	our sign	executive officer	date
DI (FH) Werner Sens	2016-05-19	VA-KU	Prof. Dr. Thomas Kratochvilla	2016-05-19

concern: tests according ÖVGW/GRIS QS-W 405/1 and PAS 1075 of the PE 100-RC piping systems

Dear Mr. Sens,

we confirm that the PE 100-RC piping systems AQUALINE RC and AQUALINE RC ROBUST are manufactured and tested according ÖNORM EN 12201-2 and ÖVGW/GRIS QS-W 405/1 (02.2016). Both piping systems are ÖVGW registered and listed in the ÖVGW quality register for water (ÖVGW/GRIS Reg.-Nr. W 1.474 und W 1.586).

Initial type testing according ÖVGW/GRIS QS-W 405/1 (02.2016) covers the all tests according PAS 1075 (2NCT, point load test, penetration test) as well as further ÖVGW specific tests.

Both piping systems are third party surveilled by the Federal Institute of Technology tgm, Plastics Technology and Environmental Engineering, according ÖVGW/GRIS QS-W 405/1 (02.2016), which covers all inspection tests of PAS 1075 (2NCT, point load test).

Best regards

Prof. DI Andreas Schmidt

27 APPLICATION OF AQUALINE RC AND ROBUST RC

- **Trench laying with a sand pad and backfill in the area around the pipe**

AquaLine pipes, due to their resistance to slow crack growth, can be laid with a pad and a reverse backfill of ballast in the area around the pipe, thus saving money on the one hand and ensuring a more stable bed of the pipes against suffosion.

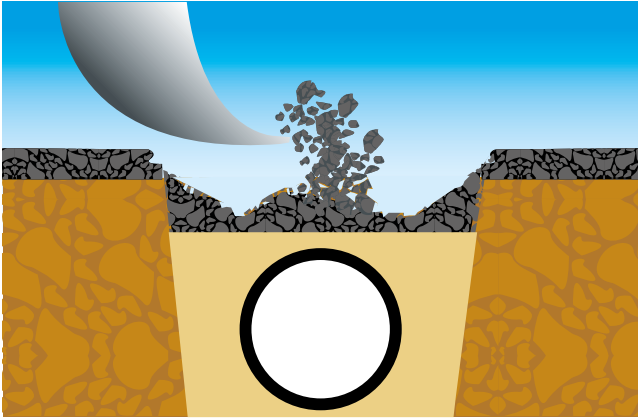

PE100RC



ROBUST RC

- **Pipe Relining**

This is a process in which a new pipe is drawn into an existing pipe. The light section of the existing pipe is larger than the outer diameter of the new pipe.



PE100RC



ROBUST RC

- **Pipe Bursting**



ROBUST RC

Laying new pipes in old pipes with a smaller diameter, by breaking the existing pipes (Pipe Bursting).

- Laying with a plow-machine / milling machine

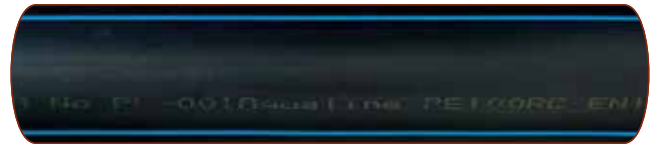

PE100RC



ROBUST RC

- Trenchless laying with horizontal wet drilling

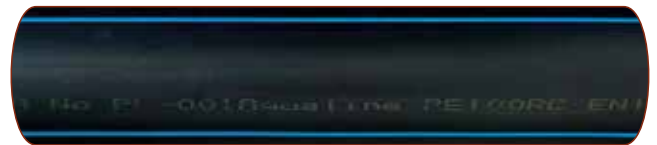

PE100RC



ROBUST RC

Horizontal wet drilling in trenchless laying (soil displacement method).

Type of pressure polyethylene pipe	Advantages	Laying of new pipelines				Replace old pipelines with new ones	
		Open laying in sandy ballast layer	Open laying without sandy ballast layer	Laying with a plow-machine / milling machine	Horizontal wet drilling in trenchless laying (soil displacement method)	Laying of new pipes in old pipes with larger diameter (Pipe Relining re-laying with distance in between pipes)	Laying of new pipes in old pipes with smaller diameter by breaking the existing pipes (Pipe Bursting)
Pressure pipes of PE 80 or PE 100	Great flexibility - minimum weight - free from corrosion - resistance to cracks	☑					
AQUALINE RC pressure pipes of PE 100-RC	Additionally + high resistance to cracks under pressure + great resistance to point loads (for example stones, pieces) + increased resistance against slow cracking		☑	☑	☑	☑	
ROBUST RC pressure pipe of PE 100-RC scratch resistant with an additional protective coating of PP	Extreme protection against mechanical damage to the surface				☑	☑	☑
Remark		-	-	-	Depending on the soil type	Depending on the condition of the old pipes	-

Maximum particle size of the sanding around the Aqualine RC and Robust RC pipes.

Pipe diameter DN [mm]	Maximum size of particles for the reverse backfill
DN63	70 mm
DN75	70 mm
DN90	70 mm
DN110	70 mm
DN125	70 mm
DN140	70 mm
DN160	70 mm
DN180	70 mm
DN200	70 mm
DN225	100 mm
DN250	100 mm
DN280	100 mm
DN315	100 mm
DN355	100 mm
DN400	100 mm

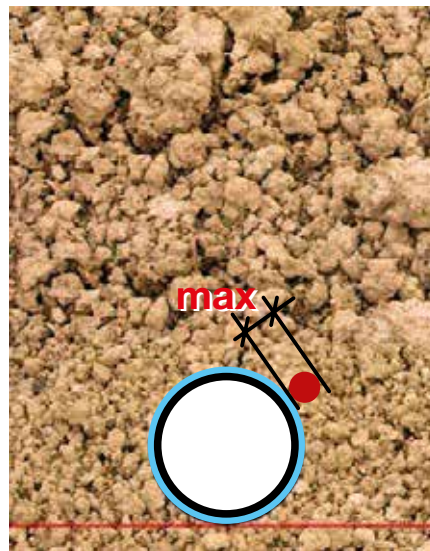



The contents and information contained in this brochure are intended for general marketing purposes only and shall not be relied upon by any person as complete or accurate. In particular, this brochure cannot replace proper expert advice on the characteristics of the products, their usage, suitability for any intended purpose, or the proper processing method. All contributions and illustrations in this brochure are subject to copyright. Unless explicitly otherwise stated, the repetition of content is not permitted. The use of photocopies from this brochure is for private and non-commercial use only. Any duplication or distribution for professional purposes is strictly forbidden. Non-Liability: PIPELIFE has established this brochure to the best of its knowledge. PIPELIFE cannot accept any liability suffered or incurred by any person resulting from or in connection with any reliance on the content of or the information contained in this brochure. This limitation applies to all loss or damage of any kind, including but not limited to direct or indirect damages, consequential or punitive damages, frustrated expenses, lost profit or loss of business.

Note: The images may differ from actual products.